

HiFi ENGINE®

For more Hi-Fi manuals and set-up information
please visit www.hifiengine.com

*Operating
Instructions*

Quartz-PLL Direct Drive
Ribbon Sendust Head

STEREO CASSETTE TAPE DECK

CT-9R

KU

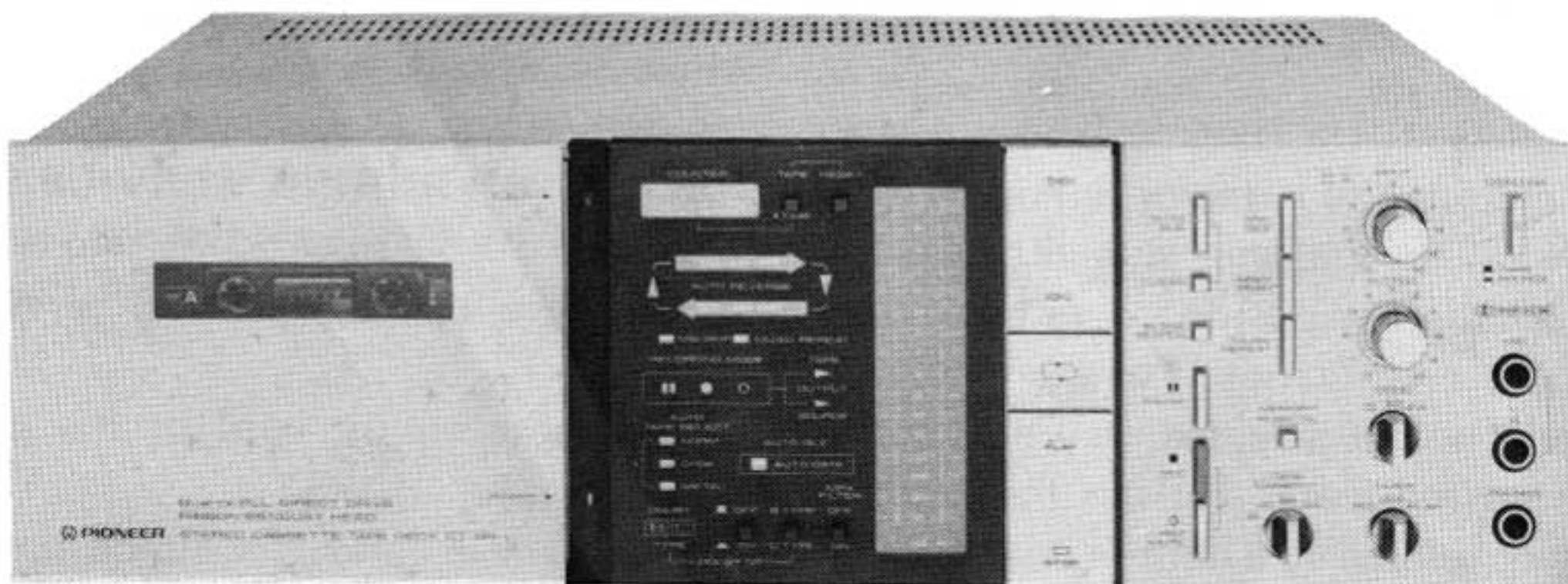

IMPORTANT NOTICE

The serial number for this equipment is located on the rear panel. Please write this serial number on your enclosed warranty card and keep in a secure area.

This is for your security.

WARNING: TO PREVENT FIRE OR SHOCK HAZARD, DO NOT EXPOSE THIS APPLIANCE TO RAIN OR MOISTURE.

 **PIONEER®**

SAFETY INSTRUCTIONS

READ INSTRUCTIONS — All the safety and operating instructions should be read before the appliance is operated.

RETAIN INSTRUCTIONS — The operating instructions should be retained for future reference.

HEED WARNING — All warnings on the appliance and in the operating instructions should be adhered to.

FOLLOW INSTRUCTIONS — All operating and use instructions should be followed.

WATER AND MOISTURE — The appliance should not be used near water — for example, near a bathtub, washbowl, kitchen sink, laundry tub, in a wet basement, or near a swimming pool, etc.

LOCATION — The appliance should be installed in a stable location.

WALL OR CEILING MOUNTING — The appliance should not be mounted to a wall or ceiling.

VENTILATION — The appliance should be situated so that its location or position does not interfere with its proper ventilation. For example, the appliance should not be situated on a bed, sofa, rug, or similar surface that may block the ventilation openings; or, placed in a built-in installation, such as a bookcase or cabinet that may impede the flow of air through the ventilation openings.

HEAT — The appliance should be situated away from heat sources such as radiators, heat registers, stoves, or other appliances (including amplifiers) that produce heat.

POWER SOURCES — The appliance should be connected to a power supply only of the type described in the operating instructions or as marked on the appliance.

POWER-CORD PROTECTION — Power-supply cords should be routed so that they are not likely to be walked on or pinched by items placed upon or against them, paying particular attention to cords at plugs, convenience receptacles, and the point where they exit from the appliance.

CLEANING — The appliance should be cleaned only with a polishing cloth or a soft dry cloth. Never clean with furniture wax, benzene, insecticides or other volatile liquids since they may corrode the cabinet.

NONUSE PERIODS — The power cord of the appliance should be unplugged from the outlet when left unused for a long period of time.

OBJECT AND LIQUID ENTRY — Care should be taken so that objects do not fall and liquids are not spilled into the enclosure through openings.

DAMAGE REQUIRING SERVICE — The appliance should be serviced by Pioneer authorized service center or qualified service personnel when:

- The power-supply cord or the plug has been damaged; or
- Objects have fallen, or liquid has been spilled into the appliance; or
- The appliance has been exposed to rain; or
- The appliance does not appear to operate normally or exhibits a marked change in performance; or
- The appliance has been dropped, or the enclosure damaged.

SERVICING — The user should not attempt to service the appliance beyond that described in the operating instructions. All other servicing should be contacted nearest Pioneer authorized service center.

DEW CONDENSATION

When the unit is moved from a cold to a warm room, or a quick temperature change occurs, condensation will form on the mechanical parts affecting performance of the unit. In such cases, leave the unit in the warmer atmosphere for approximately one hour, or gradually change the room temperature.

CONTENTS

Connections	3	Using the Tape Deck with an Audio Timer	12
Front Panel Facilities	4	Tape Deck Care	13
Cassette Tape	6	Dolby NR B/C Type System	14
Playback	7	Auto BLE Functions	14
Recording	8	Troubleshooting	15
Using the Tape Deck Functions	10	Specifications	16

CONNECTIONS

To avoid damaging other components, turn the power switch on the amplifier OFF.

Connect the accessory connection cables as shown in the figure. The upper terminals are for the left channel (L), and the lower terminals are for the right channel (R).

Play back connection: Connect the OUTPUT terminal of the tape deck to the TAPE PLAY terminal of the amplifier.

Record connection: Connect the INPUT terminal of the tape deck to the TAPE REC terminal of the amplifier.

NOTE:

Make certain connectors are pushed all the way in. An improper connection or poor contact will result in no sound, or will degrade the sound.

When connecting the remote control unit JT-216 (sold separately), insert the remote control plug firmly in the socket on the CT-9R.

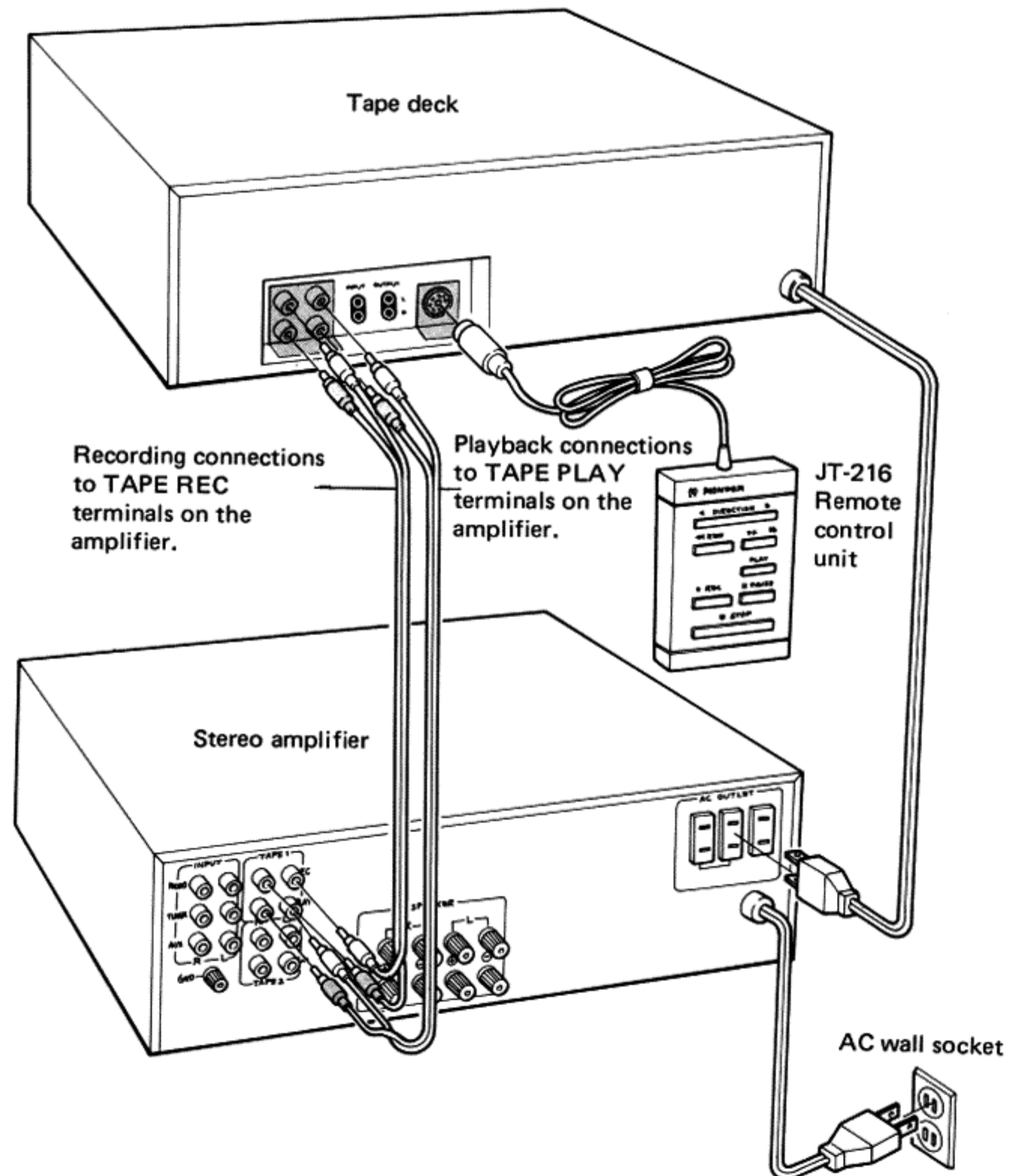

FRONT PANEL FACILITIES

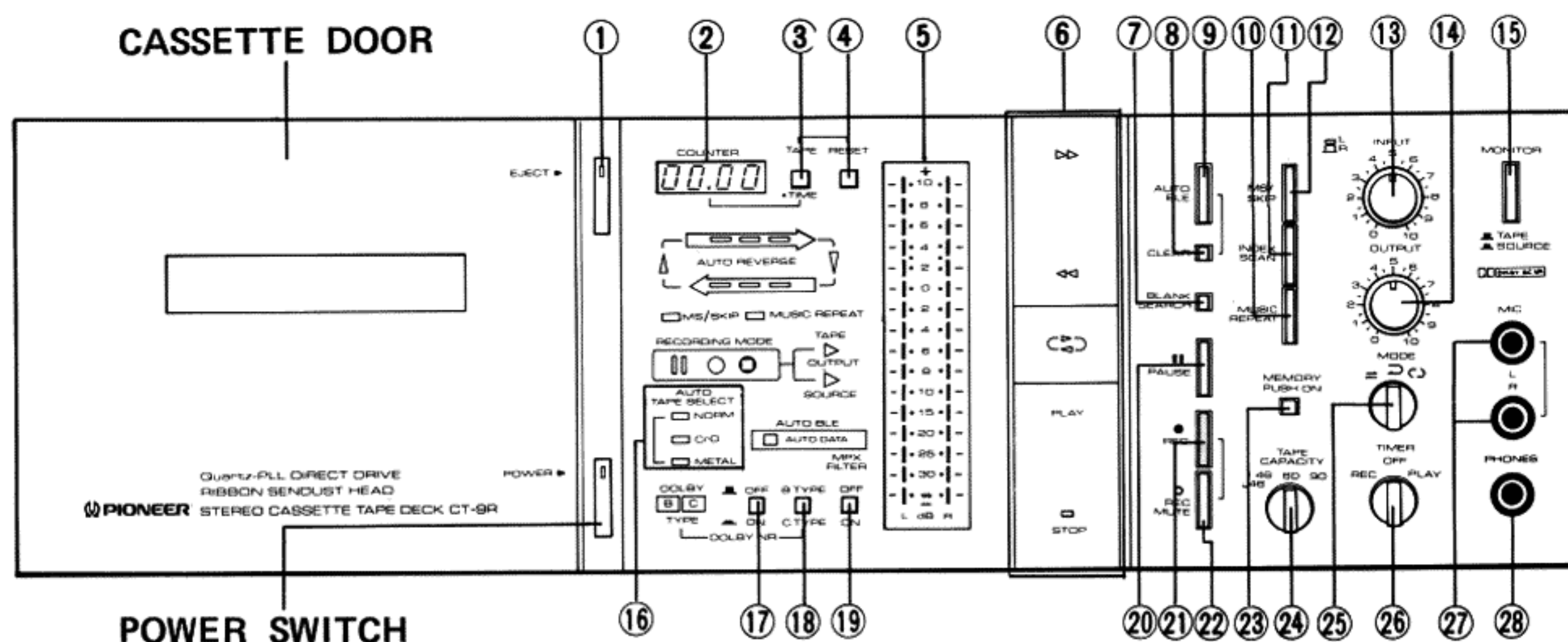

① EJECT SWITCH

Depress this switch to open the cassette door.

NOTE:

When the tape is in motion (including pause) the cassette door will not open when this switch is pressed.

② DUAL MODE COUNTER

The counter mode selector is used to switch operations from a normal tape counter mode to a mode that shows the amount of time left on the present tape. Details may be found on page 6.

NOTE:

Turning the power switch ON sets the normal tape counter operation.

③ COUNTER MODE SELECTOR

Depress this switch to select the counter mode.

④ COUNTER RESET SWITCH

Depressing this switch resets the counter to 0000.

⑤ LEVEL METER

Input-output level is shown by this indicator during recording or playback.

⑥ OPERATIONS SWITCHES

▷▷ (FAST FORWARD): Depress this switch to fast forward the tape in the direction from left to right.

◁◁ (REWIND): Depress this switch to rewind the tape in the direction from right to left.

◁▷ (DIRECTION): Depress this switch to reverse the direction of travel of tape.

▶ (PLAY): Depress this switch to start tape playback.

◻ (STOP): Depress this switch to stop tape travel.

⑦ BLANK SEARCH SWITCH

Depressing this switch puts the mechanism in the fast forward mode.

When a non-recorded area of over 8 seconds duration in the fast forward mode is detected, the mechanism stops the tape and rewinds it to the proper recording start position.

⑧ CLEAR SWITCH

Depress this switch to clear the data used by the AUTO BLE system. Bias current, recording level, and equalization are set to reference values built into the machine.

⑨ AUTO BLE SWITCH

Depress this switch to use the AUTO BLE system to automatically adjust bias current, recording level, and equalization.

⑩ MUSIC REPEAT SWITCH

Depressing this switch during tape playback causes the song now being played to be repeated. (repeat play up to eight times)

⑪ INDEX SCAN SWITCH

Depressing this switch causes the mechanism to scan in the direction that the DIRECTION switch (◁▷) is set to. When a tape has a number of songs recorded on it, the scan mechanism will stop at the beginning of each song and play about 7 seconds of it. If scan is desired during tape rewind, depress this switch along with the rewind switch (◁◁).

⑫ MS/SKIP SWITCH

When this switch is ON, depressing the fast forward switch (rewind switch if traveling in other direction) causes the mechanism to fast forward to the beginning of the next song, and restart playback from that point. When the MS/SKIP switch is on during normal playback, blank sections between songs over eight seconds long will be skipped over in the fast forward mode until the beginning of the next song, and playback will restart from that point automatically.

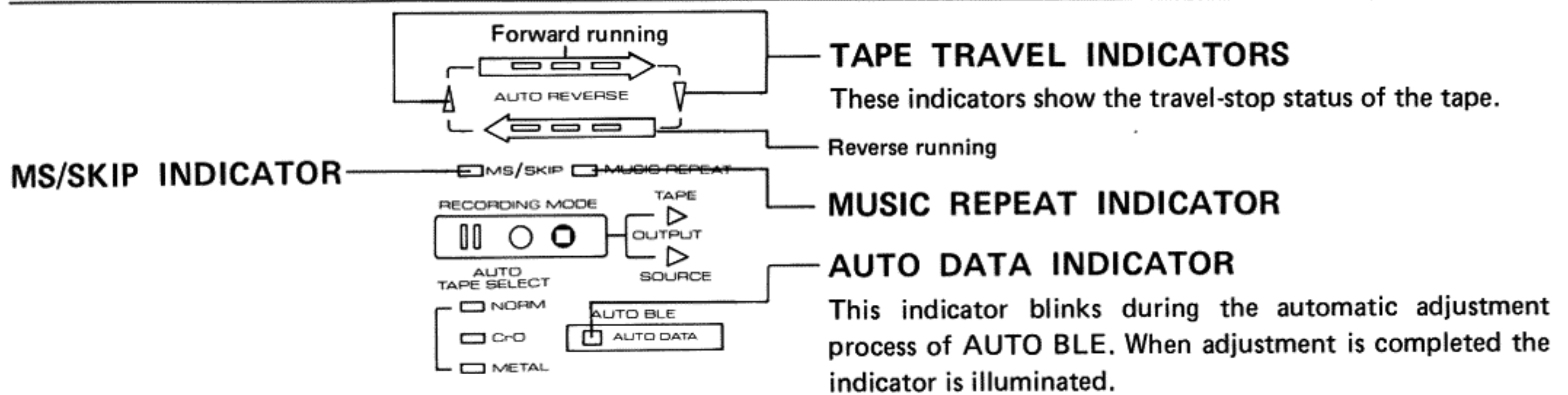



⑬ INPUT KNOB

This knob is used to adjust input level during recording. The front knob can be turned to adjust the left channel, and the backside knob can be turned to adjust the right channel independently.

⑭ OUTPUT KNOB

This knob is used to adjust output level.

⑮ MONITOR SWITCH

Use this switch to monitor recording. Depressing this switch ( SOURCE) allows the source to be monitored. In this position, the recording source is monitored before tape passes over the recording head. Returning the switch to the TAPE () position allows the tape to be monitored. Material recorded on the tape is heard directly after passing over the recording head.

⑯ AUTO TAPE SELECT INDICATOR

When a cassette tape is loaded into the unit, the sensor holes on the cassette are used to detect the type of tape inserted. Bias and equalization are then automatically set according to tape type. This indicator functions to show the type of tape in use.

⑰ DOLBY NR* ON/OFF SWITCH

Depress this switch to use the Dolby NR system during recording and playback.

⑱ B/C TYPE SELECTOR

Depress this switch to select the B type Dolby NR system or the C type system. The indicator on the left will show the appropriate selection.

⑲ MPX FILTER SWITCH

Depress this switch to record FM stereo broadcasts and TV programs using the Dolby NR system.

⑳ PAUSE SWITCH

Depress this switch to temporarily stop tape travel. This switch will not stop tape travel during fast forward or during the rewind mode. Depress the switch again to restart tape travel.

㉑ REC SWITCH

Depress this switch to start tape recording.

㉒ REC MUTE SWITCH

Depress this switch to create a non-recorded section during tape recording. For details, refer to page 10.



㉓ MEMORY SWITCH (PUSH ON)

Use this switch in conjunction with the tape counter and rewind switch (in reverse mode, fast forward switch) to automatically stop tape travel at a position set on the counter. Press the switch again to return to normal mode operation. For details, refer to page 11.

㉔ TAPE CAPACITY SELECTOR

Use this switch to convert the counter into a remaining tape time type counter. L46 is used when a large hub 46-minute tape is being played.

㉕ MODE SELECTOR SWITCH

-  : At this position, the tape is automatically stopped at the end of travel on either take up reel.
-  : In this position, the tape will reverse its direction of travel at the end of the tape in the present direction of travel. After the tape makes one round trip it is automatically stopped.
-  : In this position, playback is repeated four complete times. (four round trips)

㉖ TIMER SWITCH

This switch is used in conjunction with the timer for recording and playback.

- REC: Recording automatically commences at the time set on the timer.
- OFF: Keep in this position when timer not being used.
- PLAY: The tape will automatically be played back at the time set on the timer.

㉗ MIC JACKS (L, R)

Plug the microphones into these jacks when making microphone recordings.

㉘ PHONES JACK

Plug the headphones into this jack when monitoring tape recording, or listening to playback.

* The word "Dolby" and  are trademarks of Dolby Laboratories Licensing Corporation. Noise Reduction System manufactured under license from Dolby Laboratories Licensing Corporation.

CASSETTE TAPE

AUTO TAPE SELECTOR MECHANISM

This mechanism uses the sensor holes on the cassette tape to detect the type of tape being used. It then automatically adjusts the proper recording bias and equalization for the tape.

The sensor holes for the various tape types are shown in the figure below.

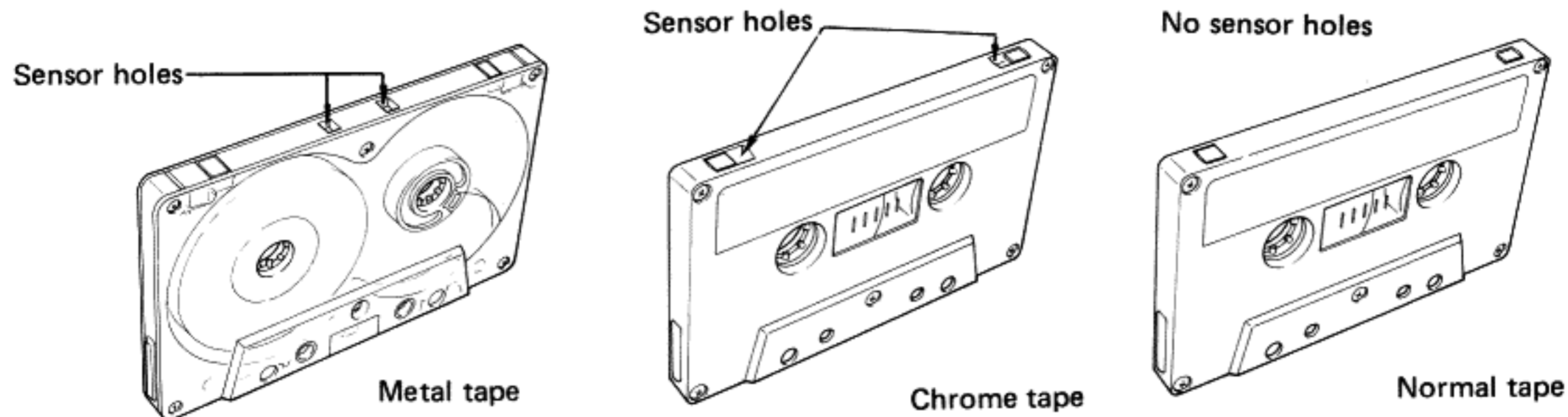

Precaution
A metal tape without a sensor hole will be adjusted to the chrome tape position. In this case, the AUTO BLE system will not function.

Large cassette hubs and Small cassette hubs

The figure shows the difference between large and small cassette hubs. Adjust the TAPE CAPACITY SELECTOR correctly in order to obtain an accurate remaining tape time.

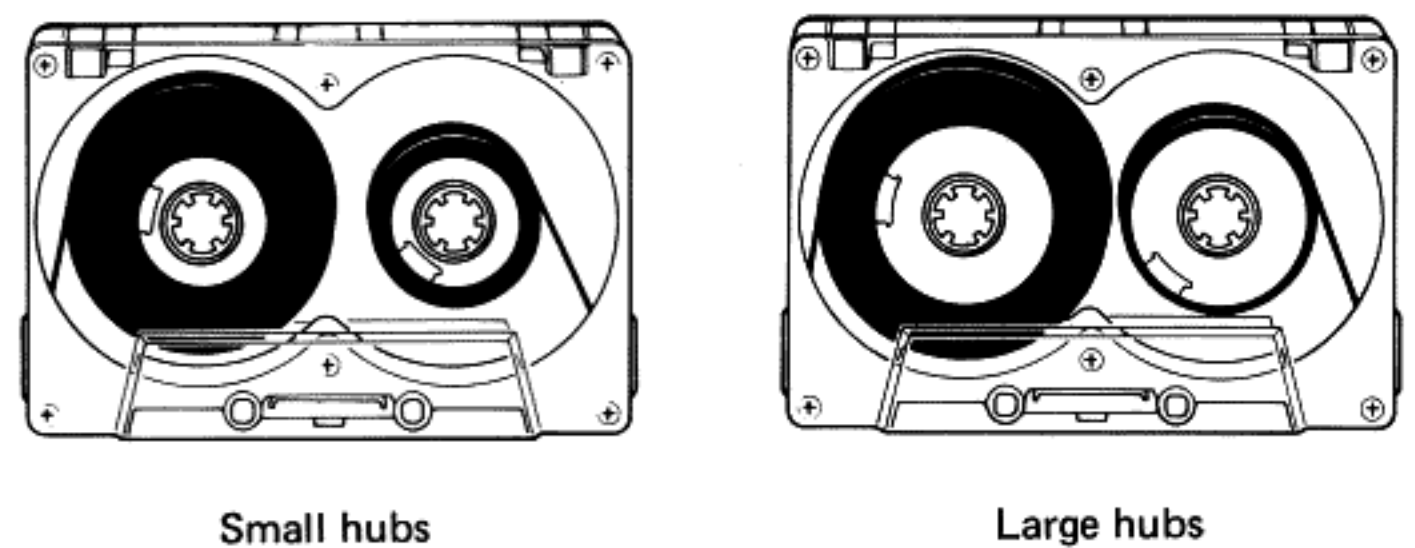

THE DUAL MODE COUNTER

This unit has a digital tape counter that can also display the amount of playback or recording time remaining during tape transport. When power is first turned on, the counter operates as a normal tape counter. To change to the remaining time display, depress the counter mode selector switch; a dot (.) will appear in the counter. When the PLAY or REC switch is depressed, the counter will display an approximate value of the remaining time. During this time, the dot flashes on and off to show the counter is calculating the remaining time. Once calculations have been completed, the dot will remain lit and the exact remaining time will be displayed.

When tape transport is interrupted before the end of the tape is reached and then started again, the process starts again, an approximate value displayed first and then the exact value a short time later. During the fast forward and rewind modes, the time indication changes in 10 second intervals, returning to 1 second intervals when the STOP switch is depressed. When the direction of tape travel is reversed, the counter automatically changes to indicate time remaining in the new direction.

- The remaining time indication varies slightly depending on the cassette in use. Also, the calculator is designed to display 00.00 while there is still a small amount of time remaining (amount varies for tape lengths and manufacturers).
- Depressing the STOP switch while the counter is still calculating (dot is flashing on and off) may prevent the counter from calculating the exact remaining time. Depress the PLAY switch again to obtain the exact value.

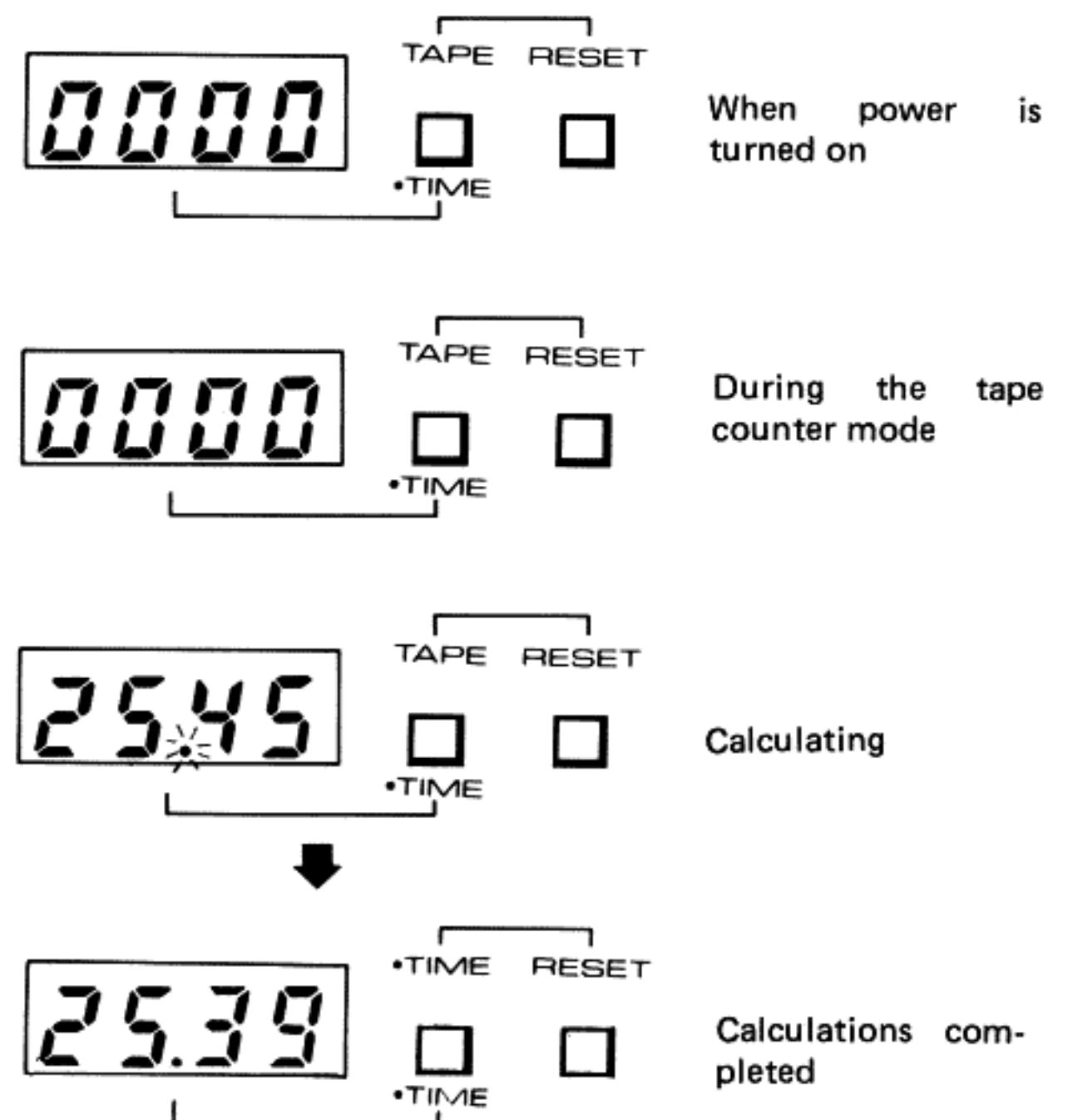

NOTE:

- The remaining time function operates only for tapes with tape capacity selector indicators (4 types). The remaining time function may not operate properly with commercially pre-recorded tapes and tapes with no time capacity markings.

PLAYBACK

ALWAYS CHECK THE FOLLOWING:

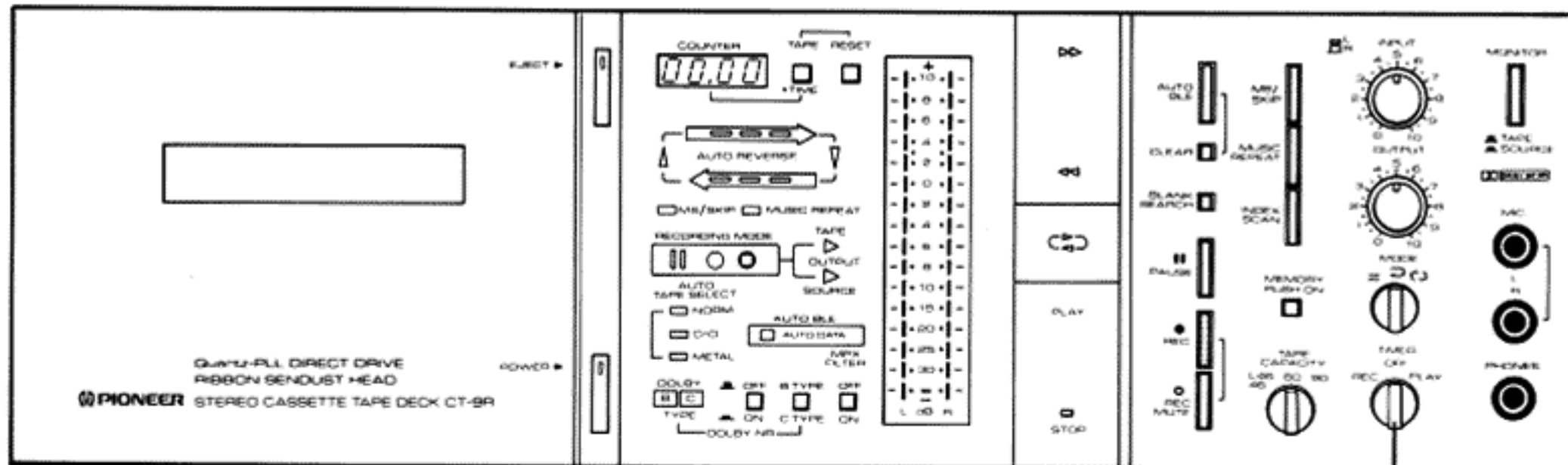

Are the heads clean?

Dirty heads degrade the sound quality of the unit. For head cleaning procedure refer to TAPE DECK CARE on page 14.

Is the TIMER switch in the OFF position?

When the TIMER switch is ON, tape travel will automatically start when the POWER switch is turned on.

PROCEDURE

1. Depress the POWER switch.
2. Load the cassette tape.

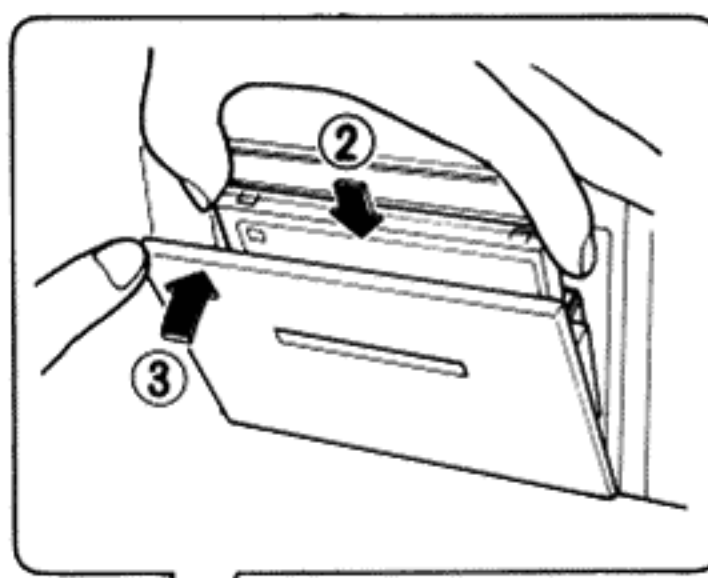

- 2 With the side of the tape you want to play back facing you and the exposed tape portion down, insert the cassette tape in the holder.
- 3 Close the cassette door.

- 1 Depress the EJECT switch

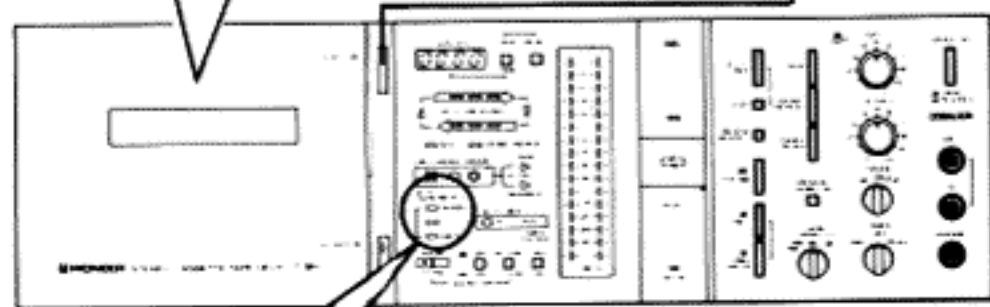

AUTO TAPE SELECT
 NORM
 CrO₂
 METAL

The tape indicator will be illuminated according to the type of tape inserted.

3. Select the DOLBY NR system.

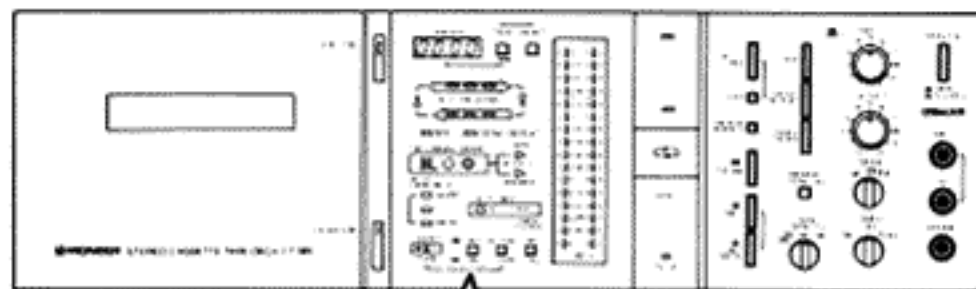

: DOLBY NR OFF
 : DOLBY NR ON
 B C : B or C type selector
 ON OFF : DOLBY NR TYPE

Select the C type DOLBY NR system for tapes recorded using that system. Select the B type DOLBY NR system for tapes recorded using that system.

4. Start playback.

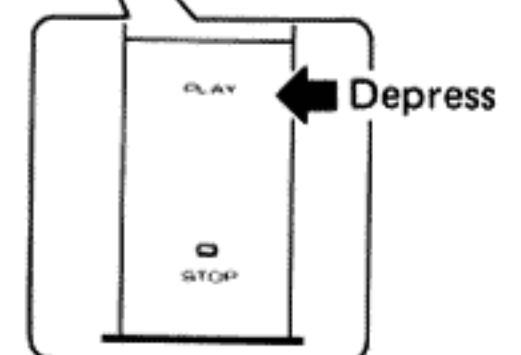
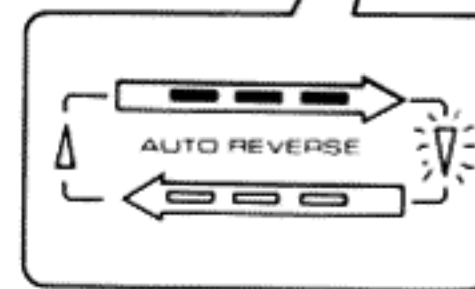
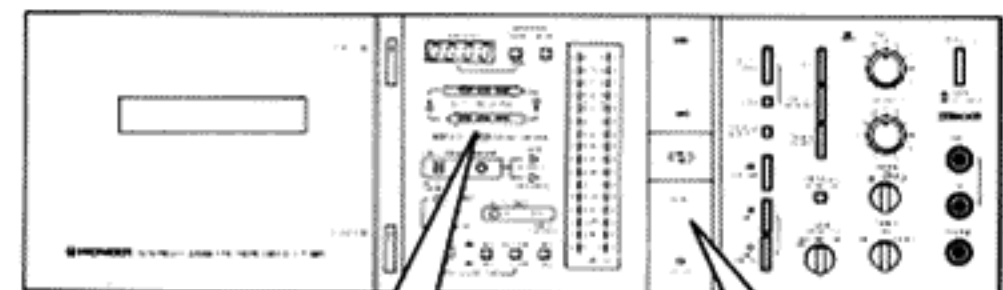

STOPPING THE TAPE TRAVEL

Depress the STOP switch.

AUTO STOP MECHANISM AND TRAVEL MODE SELECTOR SWITCH

The AUTO STOP mechanism is set to function according to the positioning of the MODE selector switch. In the single (≡) position, tape transport stops at the end of the side being played. In the auto reverse (↔) position, tape transport is automatically reversed when the end of the tape is reached and then tape transport is stopped when the end of the reverse side of the tape is reached. The repeat (↻) position automatically reverses tape transport seven times each time the end of the tape is reached and then stops tape transport.

NOTE:

The auto-reverse function may not operate if the cassette tape in use has a cleaning-type leader tape, a leader tape with a design printed on it or if there is no leader tape at all.

RECORDING

ALWAYS CHECK THE FOLLOWING:

- TIMER switch OFF.
- Certain sensor holes are provided with the tape being used.
- MONITOR switch set to TAPE.
- DIRECTION switch set to forward direction.

Are the cassette tape erasure prevention tabs broken off?
Cassette tapes cannot be recorded if the erasure prevention tabs are broken off.

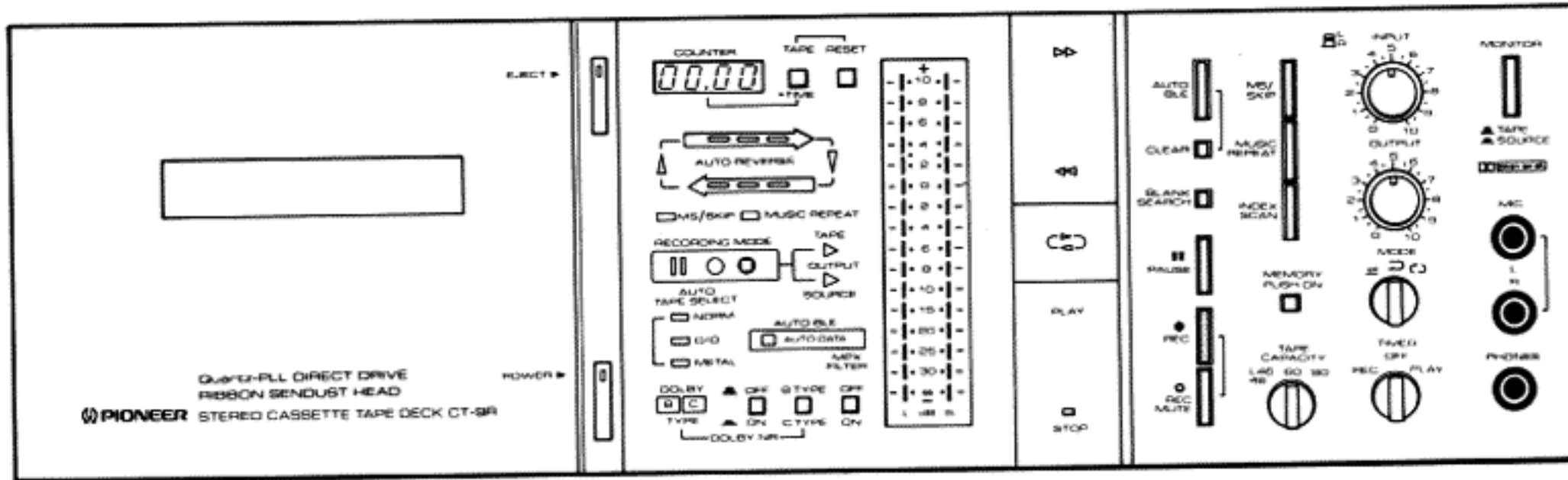

RECORDING

1. Depress the POWER switch.
2. Load the cassette tape.

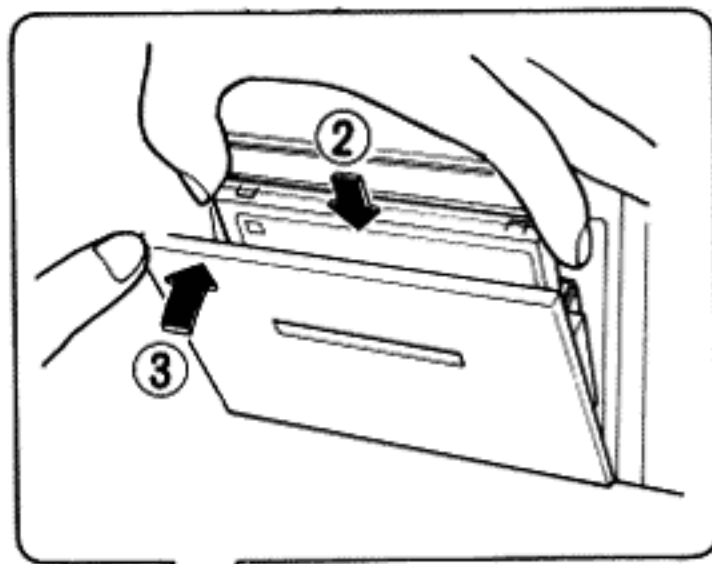

- 2 With the side of the tape you want to play back facing you and the exposed tape portion down, insert the cassette tape in the holder.
- 3 Close the cassette door.

- 1 Depress the EJECT switch

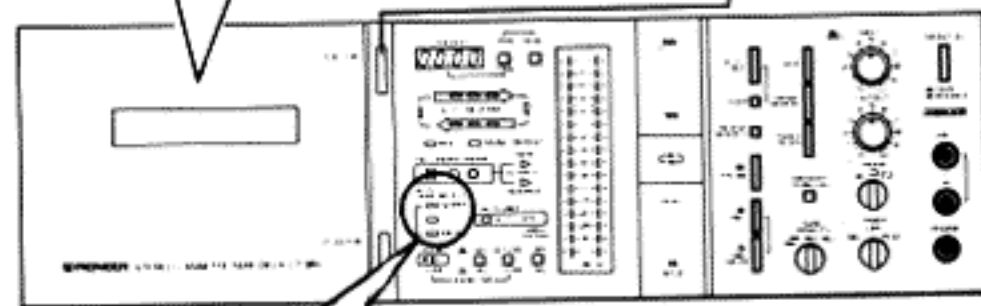

The tape indicator will be illuminated according to the type of tape inserted.

3. Depress the AUTO BLE switch.

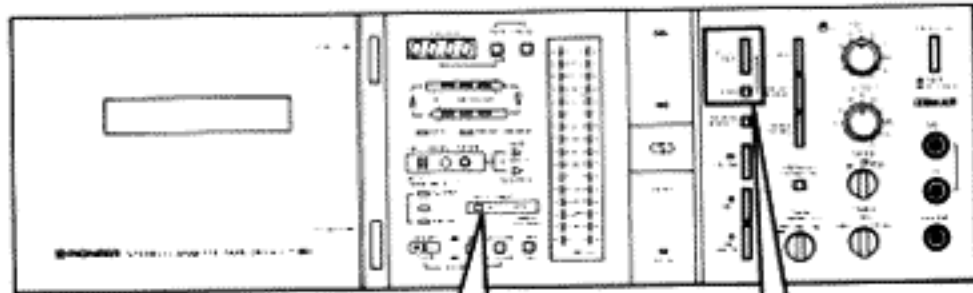

- 1 [] AUTO DATA
 - 2 [] AUTO DATA
 - 3 [] AUTO DATA
 - 4 [] AUTO DATA
- The indicator will start blinking slowly, and gradually increase in frequency. When it is adjusted properly it will be completely illuminated.

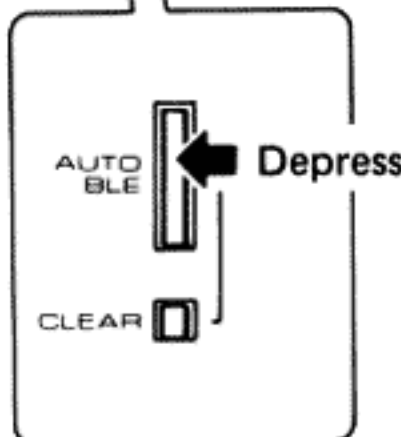

When AUTO BLE is not being used, the reference value for the tape being used will be adjusted according to the TAPE indicator position. The CLEAR switch does not require operation.

4. Place the recording mode into stand-by status.

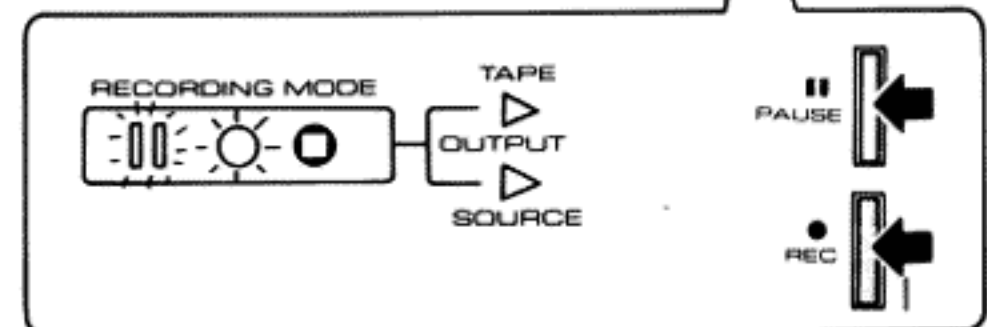
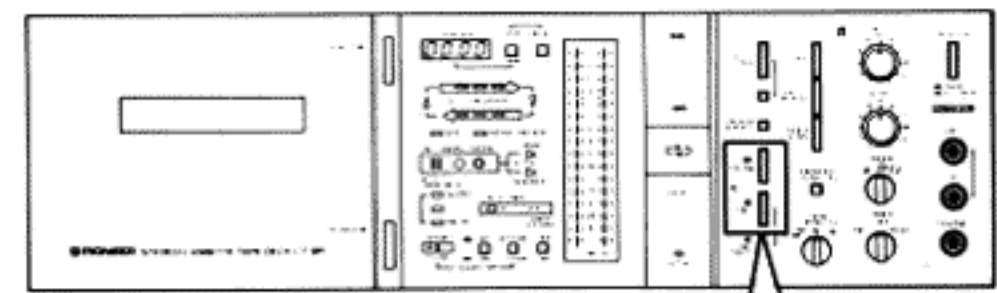

Depress the REC switch and PAUSE switch. Approximately five seconds of leader are on the first portion of the tape. Depress the PLAY switch to skip this portion.

5. Select the DOLBY NR system to be used.

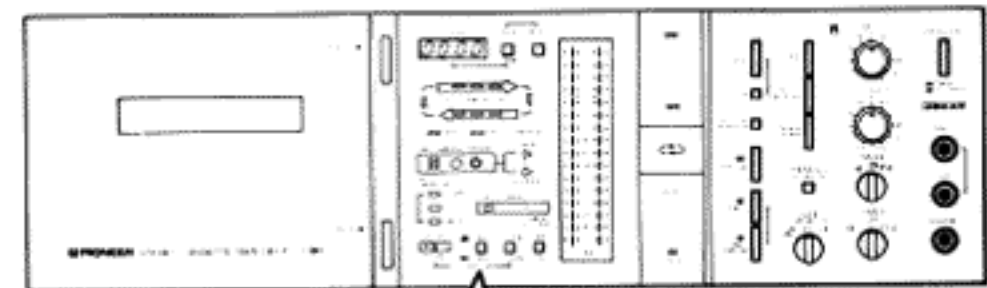

: DOLBY NR OFF
 B or C type selector
 : DOLBY NR ON

6. Adjust the recording level.

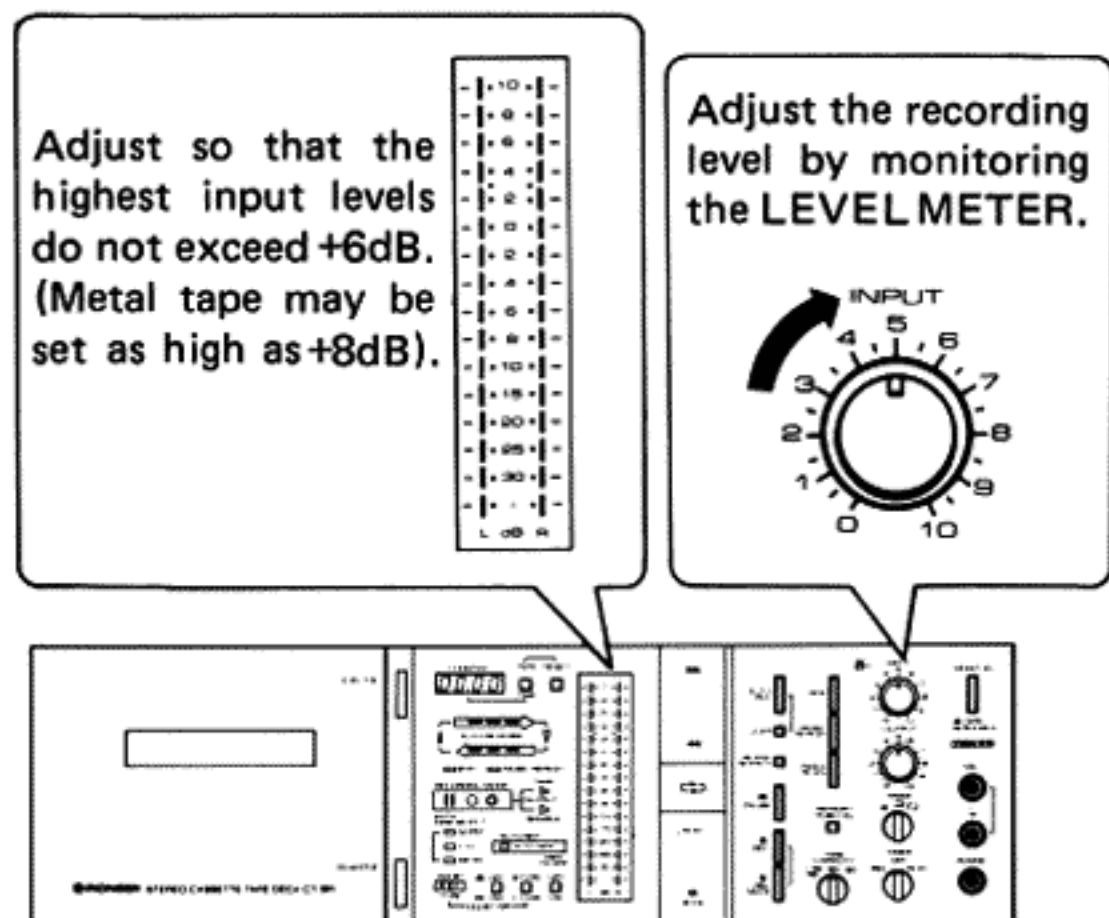

• The dots (•) between +4 and +2 on the level meters indicate the standard Dolby level.

7. Begin recording.

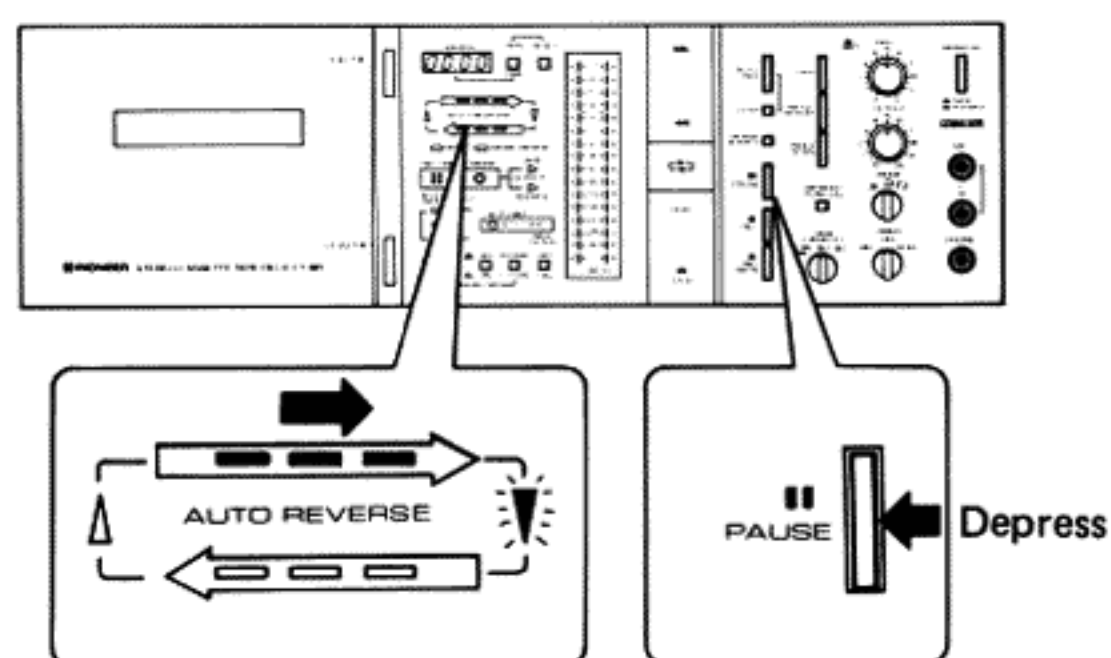

8. Monitoring the tape.

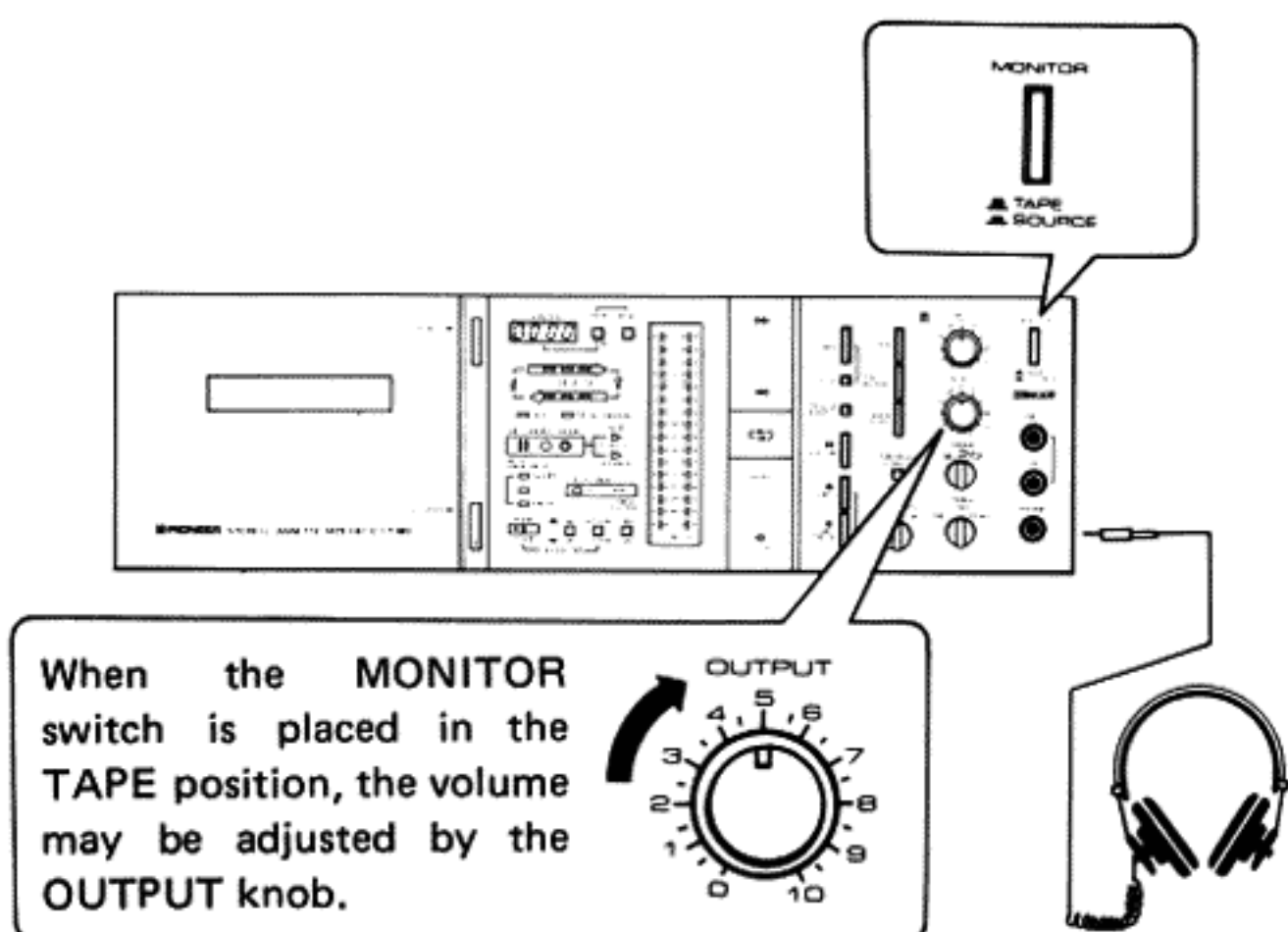

The tape deck has three heads. When the MONITOR switch is placed in the TAPE position, the tape may be monitored immediately after it passes over the recording head. In the SOURCE position, the recording source may be monitored.

NOTE:

The DIRECTION switch does not operate during recording operations.

AUTO BLE OPERATION NOTES

AUTO BLE (Auto Bias Level Equalizer Tuning System) uses an internal oscillator, and automatically records and plays back a portion of the tape for about an 8-second period and then adjusts the bias, recording level, and equalization for the particular tape being played. To assure proper system operation, observe the notes and precautions below.

1. Always use cassette tape with the proper sensing holes in the case. (This fact will be noted by the AUTO TAPE SELECT indicator)
2. The AUTO BLE system uses the first 8 seconds of a tape as an operating area in which it records signals used for adjustment purposes. Always make certain it is permissible to erase this area. Also, if a tape is used with the erasure prevention tabs broken off, AUTO BLE will not function.
3. Make certain the MEMORY switch is in the OUT position. If this switch is depressed while the AUTO BLE function is operating the tape may stop during rewind for proper AUTO BLE operation.
4. Make certain the MS/SKIP switch is in the OUT position. If this switch is depressed while the AUTO BLE function is operating the tape may stop during rewind for proper AUTO BLE operation.
5. The AUTO BLE switch operates even during tape transport. However, if the tape transport mode is changed, AUTO BLE operation will stop and tape transport will be changed to the new mode (stop, fast forward, etc.).
6. If the AUTO DATA indicator extinguishes during AUTO BLE operations, it is an indication that adjustment is not possible. If the correct TAPE indicator is illuminated fast forward the tape and attempt adjustment in another adjustment area. If proper adjustment cannot be obtained in this area also, set reference value (without using AUTO BLE).

USING THE TAPE DECK FUNCTIONS

1. REC MUTE SWITCH

Depressing this switch during recording cuts out the sound from the recorded source. Use this function while recording radio broadcasts, TV programs, etc. to cut out commercials and other unwanted programs. It is also convenient to use while making recordings from records to cut out the transient caused by the stylus lowering onto the record. Also, this function is used to create the four seconds non-recorded section used by the MUSIC REPEAT, MS/SKIP, and INDEX SCAN functions for detection purposes.

When the portion to be cut out is of long duration, use this switch in conjunction with the PAUSE switch.

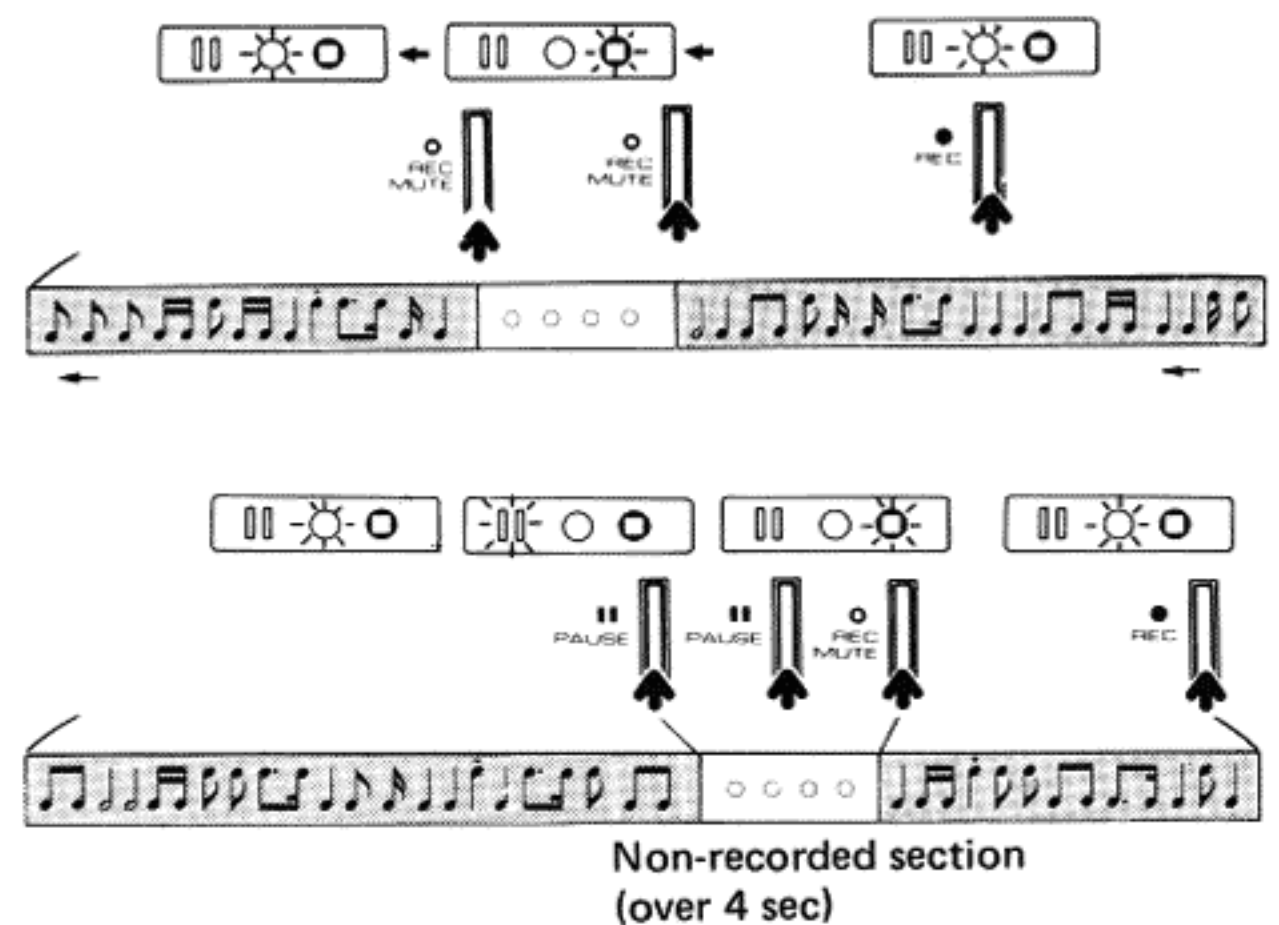

2. MS/SKIP SWITCH

Use this switch to quickly locate the beginning of a recorded portion or to skip over long non-recorded portions.

Locating the start of the next song

Depress the MS/SKIP switch and fast forward switch. When a non-recorded section is detected, playback will start at the beginning of the next recording section.

Depress the REWIND switch to hear the song you are currently playing once again.

Using during tape play back mode

When the MS/SKIP switch is ON during normal tape playback, non-recorded sections between songs of over eight seconds duration will be skipped over by fast forwarding tape.

When the MODE selector is set to the \Rightarrow or \Leftarrow position and there is a long section of blank tape at the end(s) of the tape, the unit will automatically proceed in the fast forward mode to the first song on the other side, skipping over all blank sections including the leader tape to save time.

Depress the MS/SKIP switch once again to deactivate the skip function.

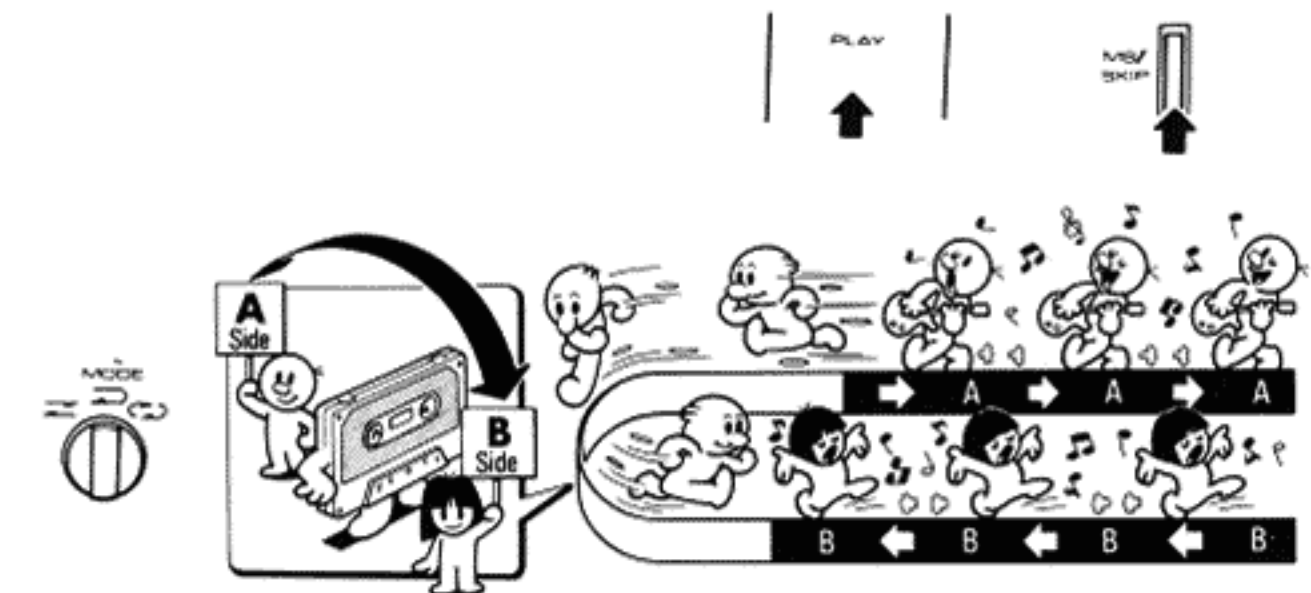
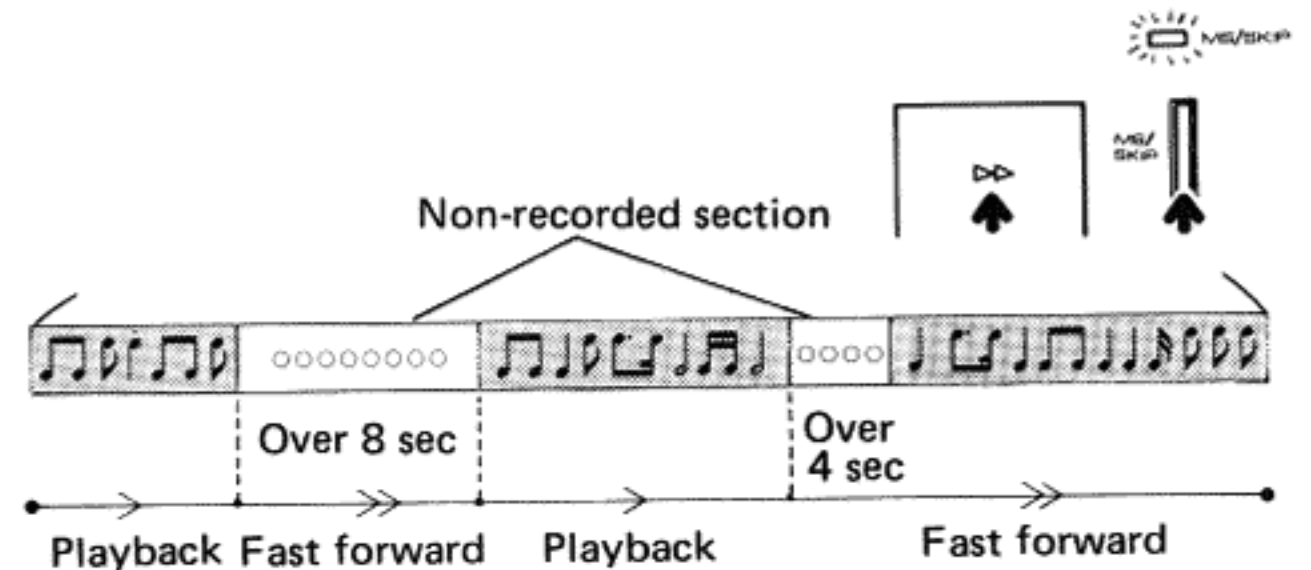

3. MUSIC REPEAT SWITCH

Use this function to hear one song on a pre-recorded cassette repeatedly.

When this switch is pressed during tape playback, the non-recorded section in front of and at the end of the song will be detected, and the present song will be repeated eight times.

Depress one of the OPERATIONS switches to deactivate the music repeat function. Note that depressing the PAUSE switch stops tape transport but does not cancel the music repeat function. When the PAUSE switch is depressed again, music repeat playback will continue.

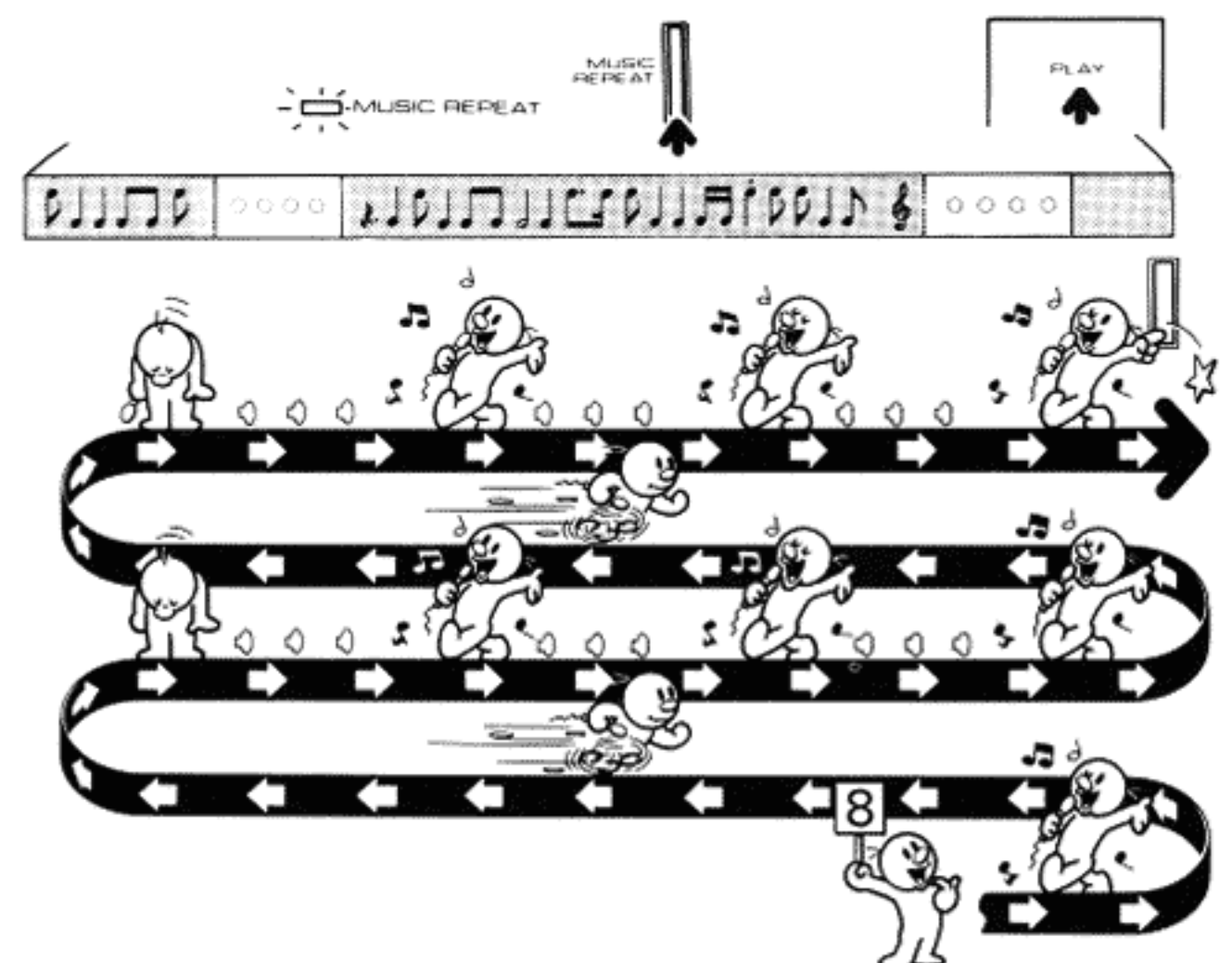

4. INDEX SCAN SWITCH

Use this function to find out what songs are recorded on a tape containing a number of programs. Depressing this switch sets the deck in the fast forward mode. Each time a non-recorded section is detected (blank gap between programs), tape travel stops and the first seven seconds of the program on the tape until index scan is deactivated.

To operate INDEX SCAN in the reverse direction, depress the fast forward or rewind switch to reverse the direction of tape travel.

Depress the STOP switch to deactivate the index scan function. Index scan can also be cancelled by depressing the PLAY switch to return to the normal playback mode.

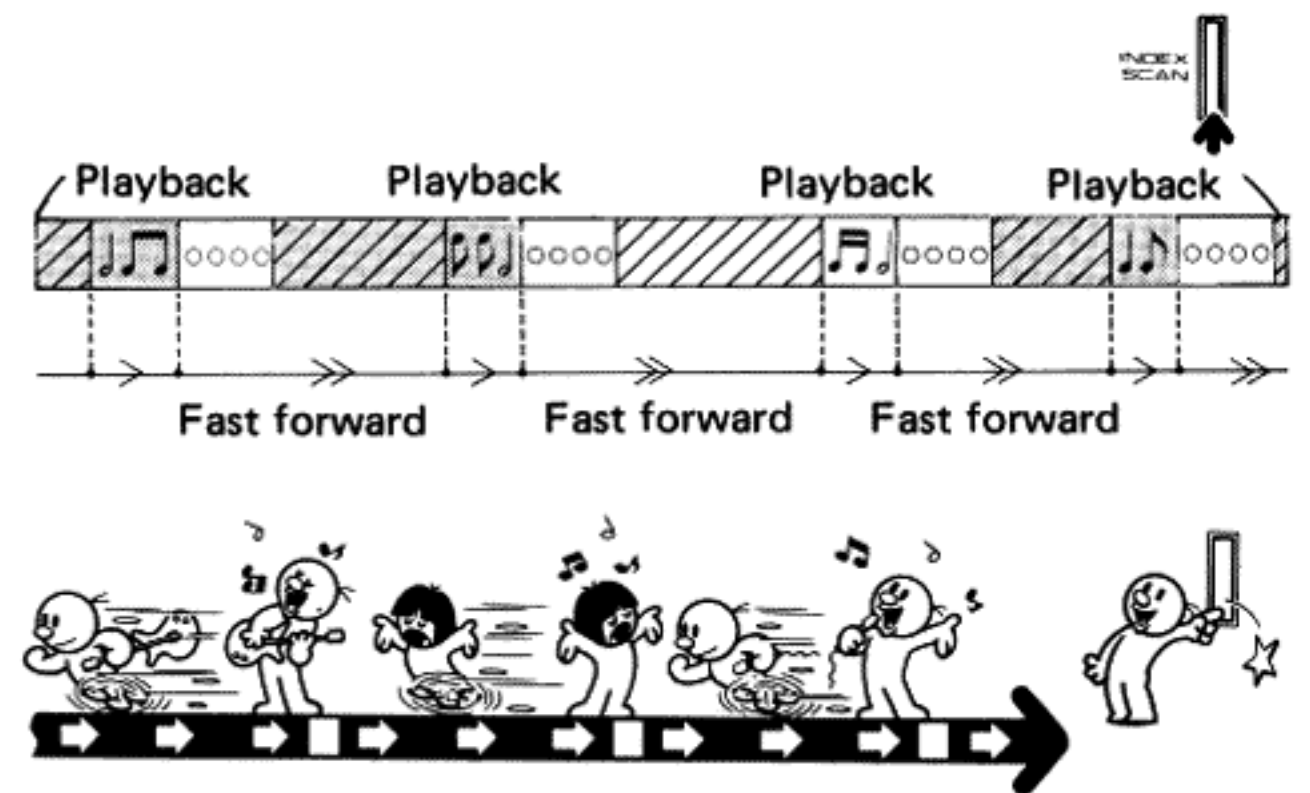

5. BLANK SEARCH SWITCH

Use this switch to locate the beginning of an area where recording is possible on a tape that has been partially recorded. Depressing this switch causes the tape to fast forward. When a non-recorded area of over eight seconds duration in fast forward mode is detected, the tape will rewind to a position creating a four second blank area from the last recorded section and stop.

When a new tape is used, this function can be used to skip over the leader tape portion and locate the proper position for recording to begin.

NOTE:

The unit may not operate normally if the DIRECTION switch is depressed during blank search operation.

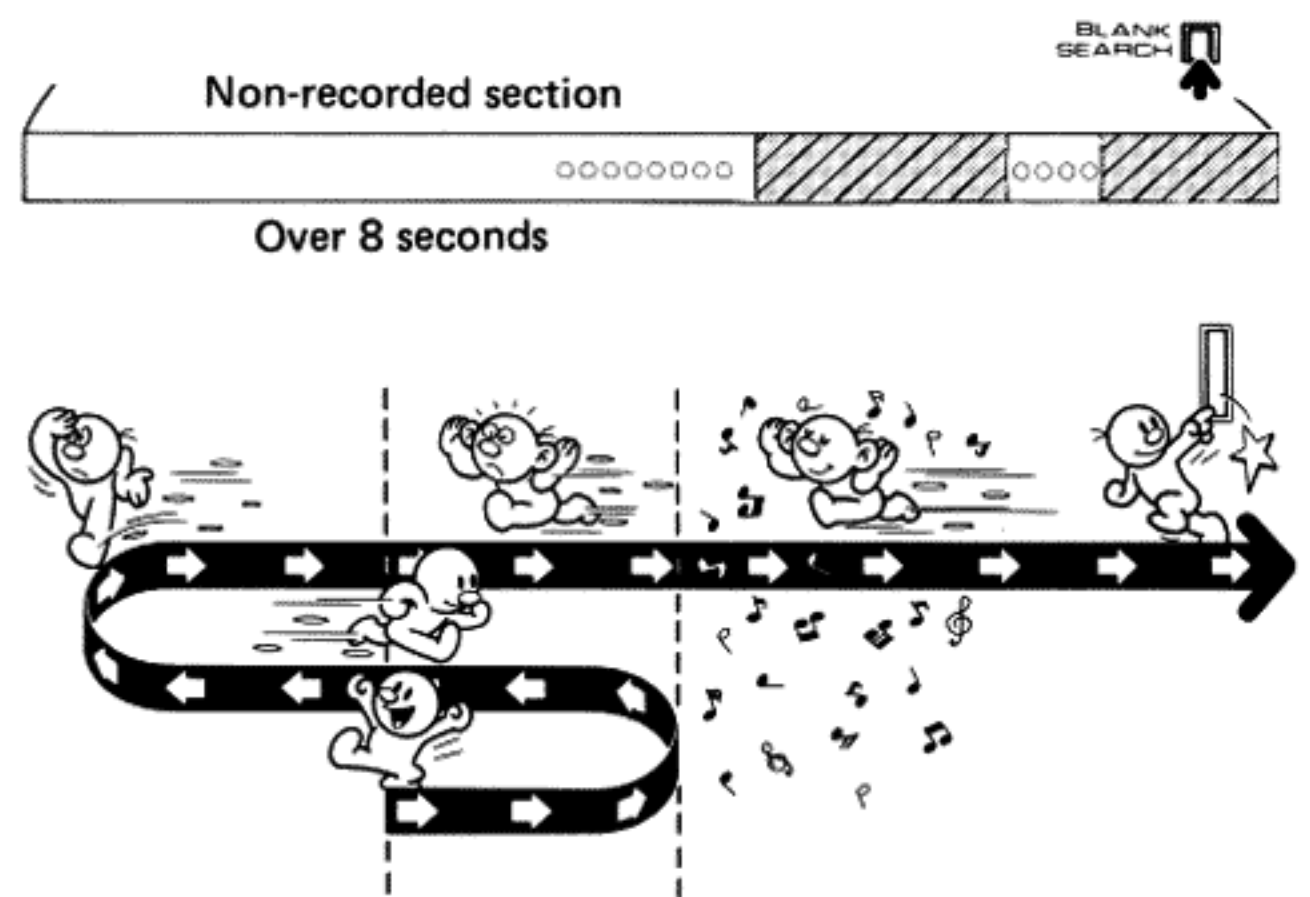

6. MEMORY SWITCH

Use this function to automatically stop the tape at a desired position. The position is set by depressing the RESET switch at the position to which you want to return, setting the counter to 0000 and depressing the MEMORY switch. When the end of the tape is reached and REWIND or FAST FORWARD switch is depressed, tape will be wound to the 9999 (rewind) or 0001 (fast forward) position.

NOTE:

If the TIMER switch is in the REC position, memory stop function can not be performed.

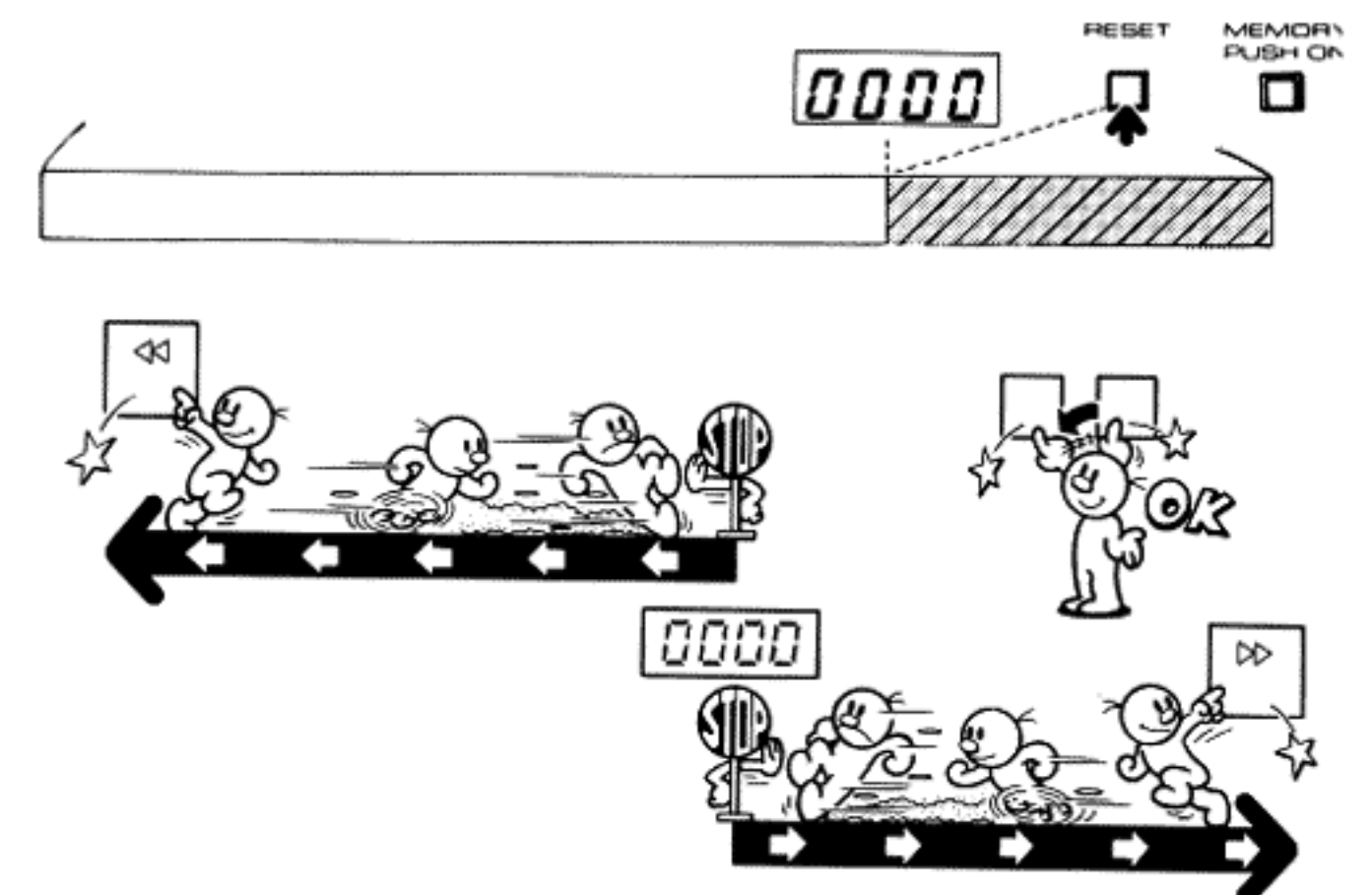

FUNCTION NOTES AND PRECAUTIONS

1. When the MS/SKIP, MUSIC REPEAT, INDEX SCAN, and BLANK SEARCH functions are used, proper performance will not be obtained unless there are non-recorded sections of approximately 4 seconds duration between songs. These sections should be created when making the recording by using the REC MUTE SWITCH.
2. When the BLANK SEARCH, INDEX SCAN, or MUSIC REPEAT switch is placed ON, the MS/SKIP function is inoperable.

3. Depressing the >>> (FAST FORWARD), <<< (REWIND), PLAY, or STOP switch overrides the function switches and become the mode of tape travel.
4. When the MS/SKIP, BLANK SEARCH, INDEX SCAN, or MUSIC REPEAT switch is placed ON, the MEMORY STOP function is inoperable.

NOTE:

The INDEX SCAN and BLANK SEARCH switches do not operate when the unit is in the recording mode or the pause mode.

USING THE TAPE DECK WITH AN AUDIO TIMER

The tape deck may be used in conjunction with an audio timer (e.g.: Pioneer model DT-510) for automatically starting a recording or playback at the time set on the recorder.

Connect the power cord as shown in the diagram below. When the system is connected as shown below, power will be controlled by the Audio Timer.

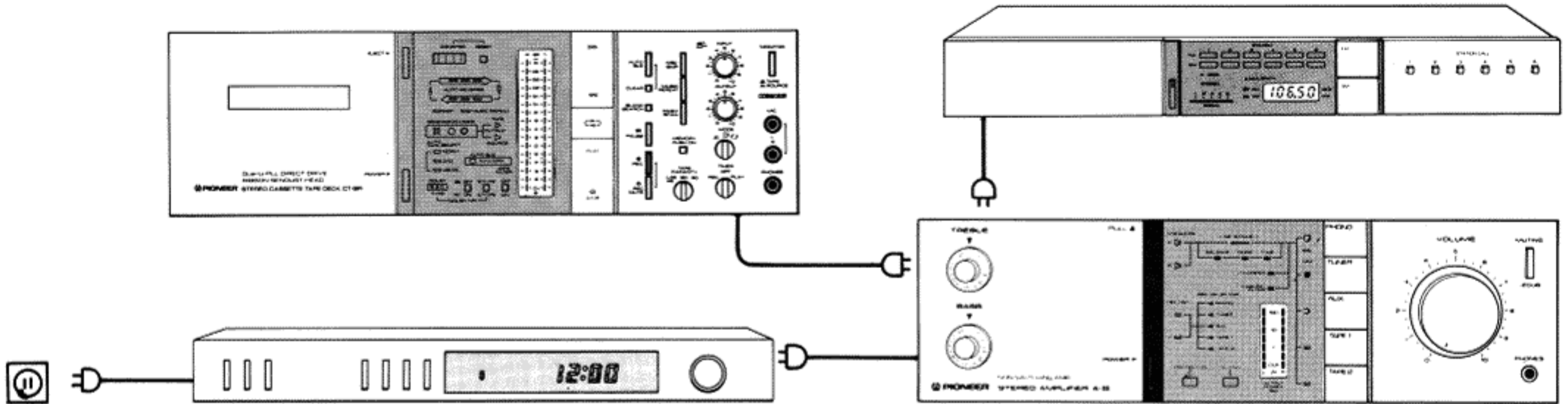

OPERATING PROCEDURES FOR THE VARIOUS COMPONENTS:

Component Operating Procedures	Recording of broadcast to commence at the specified time (unattended recording)	Playback to commence at specified time (automatic playback)
Audio timer	<ul style="list-style-type: none"> Turn the power switch of each component ON. (timer controls power) 	
Amplifier	<ul style="list-style-type: none"> Set the function to TUNER. 	<ul style="list-style-type: none"> Set to tape playback (TAPE MONITOR SWITCH etc.)
Tuner	<ul style="list-style-type: none"> Tune to the desired station. 	<ul style="list-style-type: none"> Turn the power switch OFF.
Tape deck	<ul style="list-style-type: none"> Insert a cassette tape and adjust recording level. (refer to page 9 for details) 	<ul style="list-style-type: none"> Insert the tape to be played back, and position the TAPE MONITOR SWITCH to the TAPE position and the OUTPUT KNOB should be adjusted.
↔ (DIRECTION) switch	<ul style="list-style-type: none"> Set in the forward direction. 	<ul style="list-style-type: none"> Match with the direction of playback.
Amplifier	<ul style="list-style-type: none"> Position the volume knob to 0. 	<ul style="list-style-type: none"> Position the volume knob to the normal position.
Audio timer	<ul style="list-style-type: none"> Set the desired start time and stop time. 	<ul style="list-style-type: none"> Set the timer so that the power will be supplied to the complete system at the time set. (at this time power is cut off to all components except the audio timer)
TIMER Switch	<ul style="list-style-type: none"> Set to the REC position. 	<ul style="list-style-type: none"> Set to the PLAY position.

Audio timer notes and precautions

- When the TIMER switch is placed to the REC position for unattended recording, AUTO BLE operations are automatic. The tape cassette however, must have the proper sensing holes in the case.
- The timer should be set to come on slightly ahead of the time recording is to start; and set to go off slightly after the desired time.

NOTE:

Automatic recording (while you're away) can be done on only one side of the cassette (even if the mode selector is in the ↔ or ↔ position).

TAPE DECK CARE

To obtain optimum performance from your tape deck, perform occasional cleaning and maintenance following the below listed procedures.

CLEANING THE HEADS

The heads, capstans, and pinch rollers shown in the Fig. 2 collect dust, dirt, and particles from the tape as the tape travels over this section. The heads are particularly important; dirty heads result in poor head to tape contact, this in turn degrading the sound signal, upsetting stereo balance, and causing fluctuations in tape speed. Periodic cleaning, however, will eliminate this problem. Clean these areas with a commercial head cleaner and cotton swab, or use a soft cloth dipped in a commercially available cleaning solvent.

CLEANING THE PINCH ROLLERS

When cleaning the pinch rollers, put the deck in the playback mode so the rollers are turning. Follow the steps listed below:

1. Dampen a cotton swab or other suitable instrument with a cleaning fluid (or absolute alcohol).
2. Turn the power ON and set the MODE selector switch to the = position.
3. Remove the cassette door from the cassette holder by pulling the door outward (Fig. 1).
4. Depress the EJECT switch to open the cassette holder.
5. Depress the DIRECTION switch to the forward mode and then depress the PLAY switch while pushing in the third pin from the left on the top of the cassette holder. The forward direction pinch roller (on the right side) will come up and begin to rotate. Clean the pinch roller and capstan as they rotate (Fig. 3).
6. Set the DIRECTION switch to the reverse mode. The reverse direction pinch roller (on the left side) will come up and begin to rotate. Clean in the same manner as 5. The auto-stop mechanism will return the reverse pinch roller to the recessed position in about four seconds. If you need more time to clean it, depress the PLAY switch again.

DEMAGNETIZING THE HEADS

After using the cassette over a period of time, the recording head will become magnetized. This causes loss of high frequency response and introduces noise into the sound signal system. The heads should be periodically demagnetized using a Head Eraser. For details on the Head Eraser please refer to the instruction manual accompanying the device.

NOTE:

Do not place a screwdriver or any other metal or magnetic object in contact with the heads.

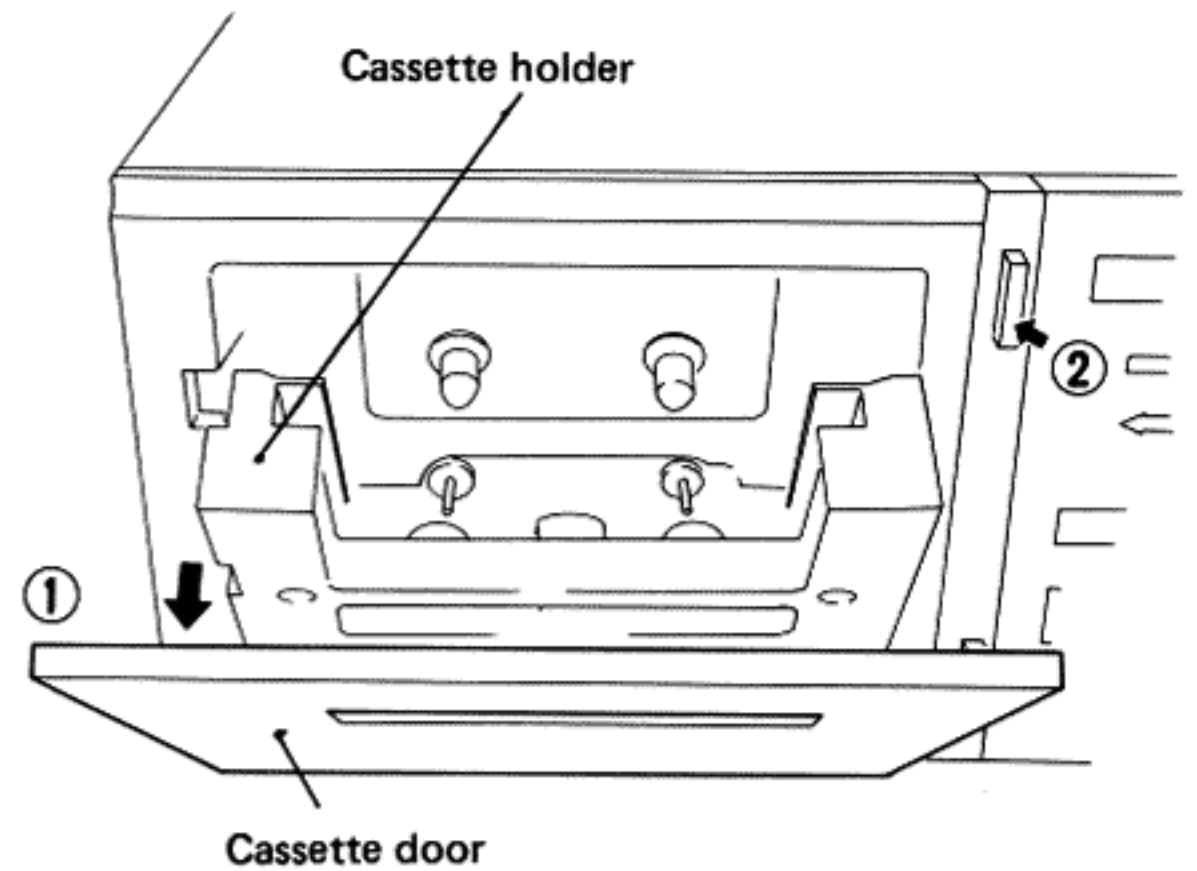

Fig. 1

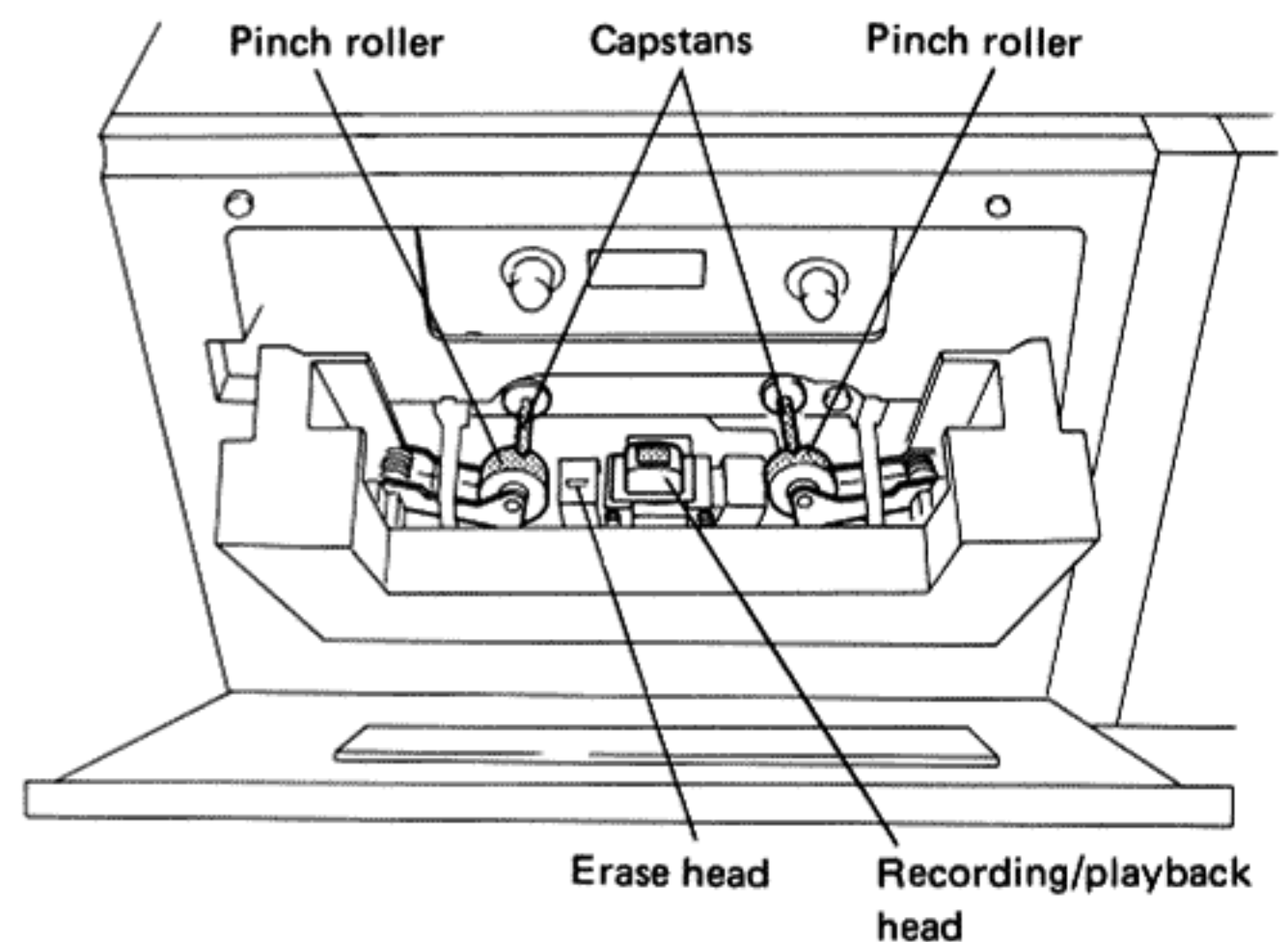

Fig. 2

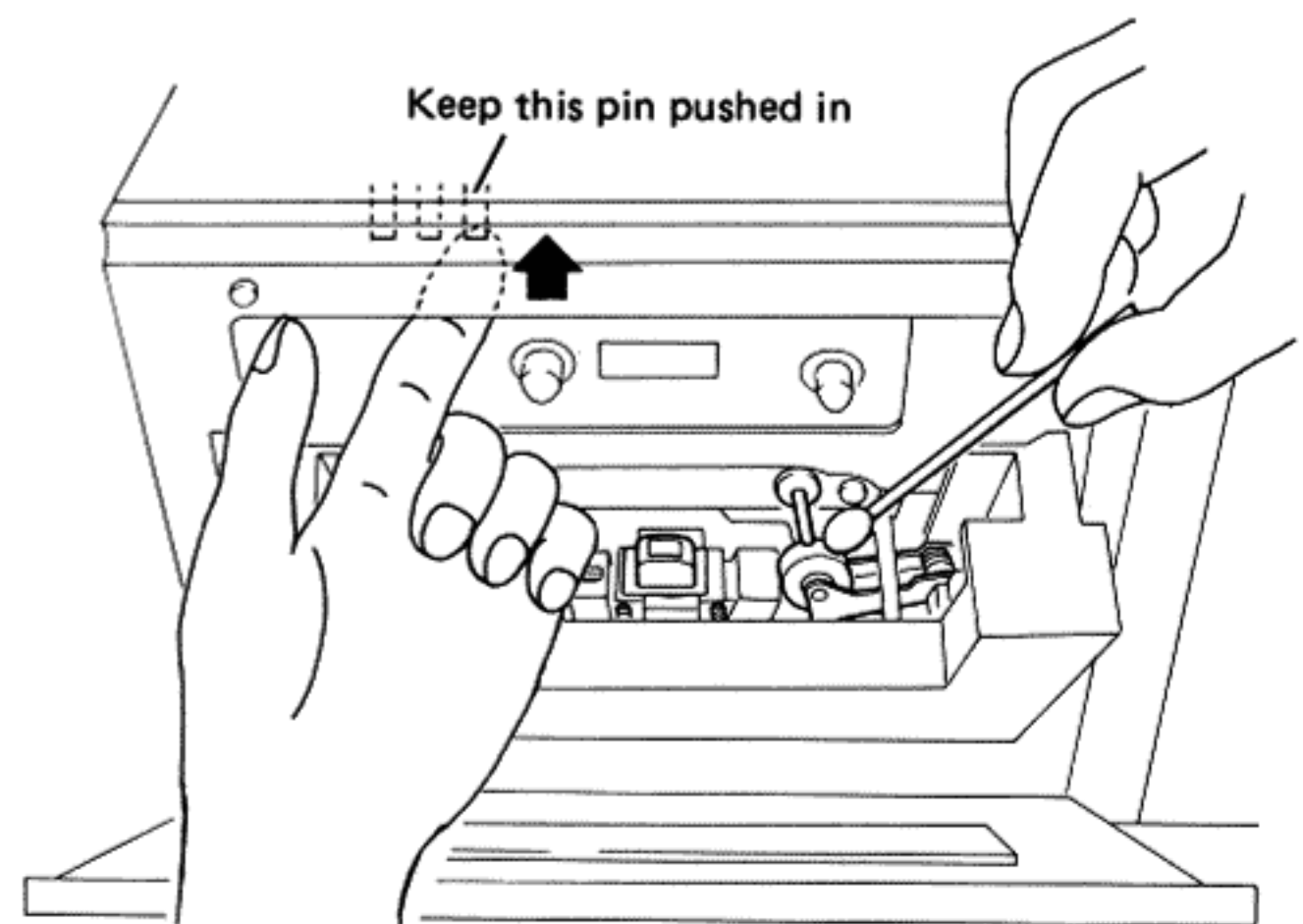

Fig. 3

NOTE:

Always turn the power switch of the amplifier OFF when performing cleaning and demagnetizing operations.

DOLBY NR B/C TYPE SYSTEM

The Dolby B type NR system is widely used as a noise reduction method in recording and playback of cassette tapes.

The B type NR system is used to reduce the tape hiss noise found in high frequency components. When a relatively low level signal is recorded, the high frequencies are boosted, and the boosted area is attenuated during playback. Thus, hiss noise is reduced. This process is automatically performed relative to the size of the input signal, and an improvement in S/N ratio of up to 10dB is obtained. For recording and playback of normal broadcast programs, this method is highly effective. However, a higher amount of noise reduction is beneficial in recording program sources with a wide dynamic range.

The basic principle of the C type NR system is the same as that for the B type. It is however an additional step that

the processor goes through. Dividing the processor into a high level and low level configuration broadens the operating band of the C type two octaves over that of the B type system. Additionally, a SPECTRAL SKEWING NETWORK attenuates ultra-high frequency signals, and an ANTI-SATURATION NETWORK improves the saturation level and results in a highly stable decoder. This results in a noise reduction improvement of 20dB.

NOTES:

- Tapes recorded using the C type Dolby NR system perform with good results when played back on a tape deck having only the B type system built in.
- Tapes recorded using the B or C type Dolby NR system should be played back with the tape deck set to the position corresponding to the type of Dolby system used for recording.

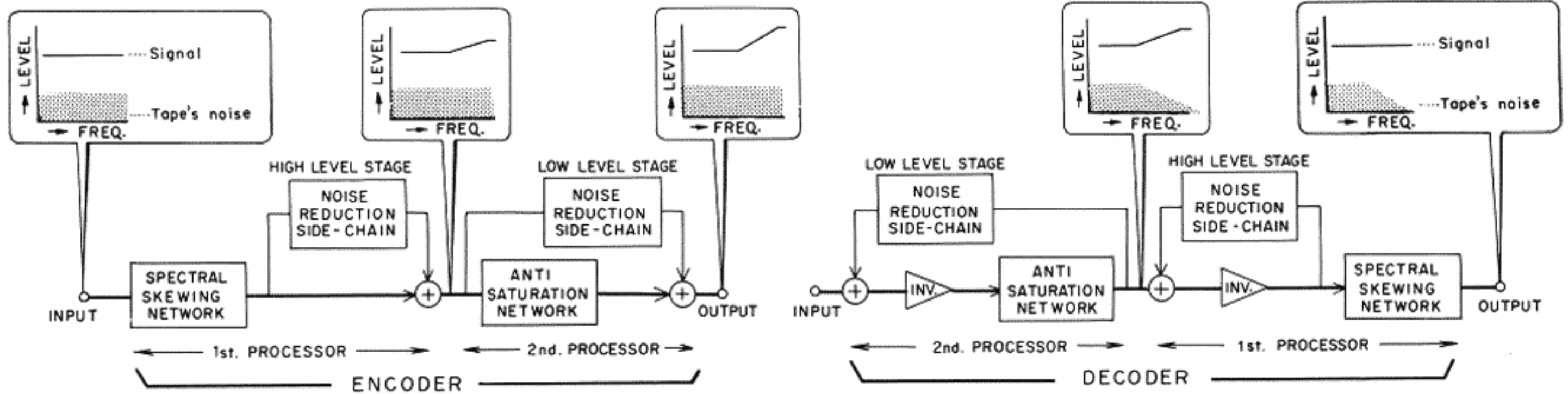

AUTO BLE FUNCTIONS

AUTO BLE is an abbreviation for Automatic Bias Level Equalizer Tuning system, and functions using a microprocessor to automatically adjust ideal bias current, recording level, and recording equalization depending upon the type of tape being used. The process which the AUTO BLE system goes through in order to accomplish this adjustment is shown in the steps below.

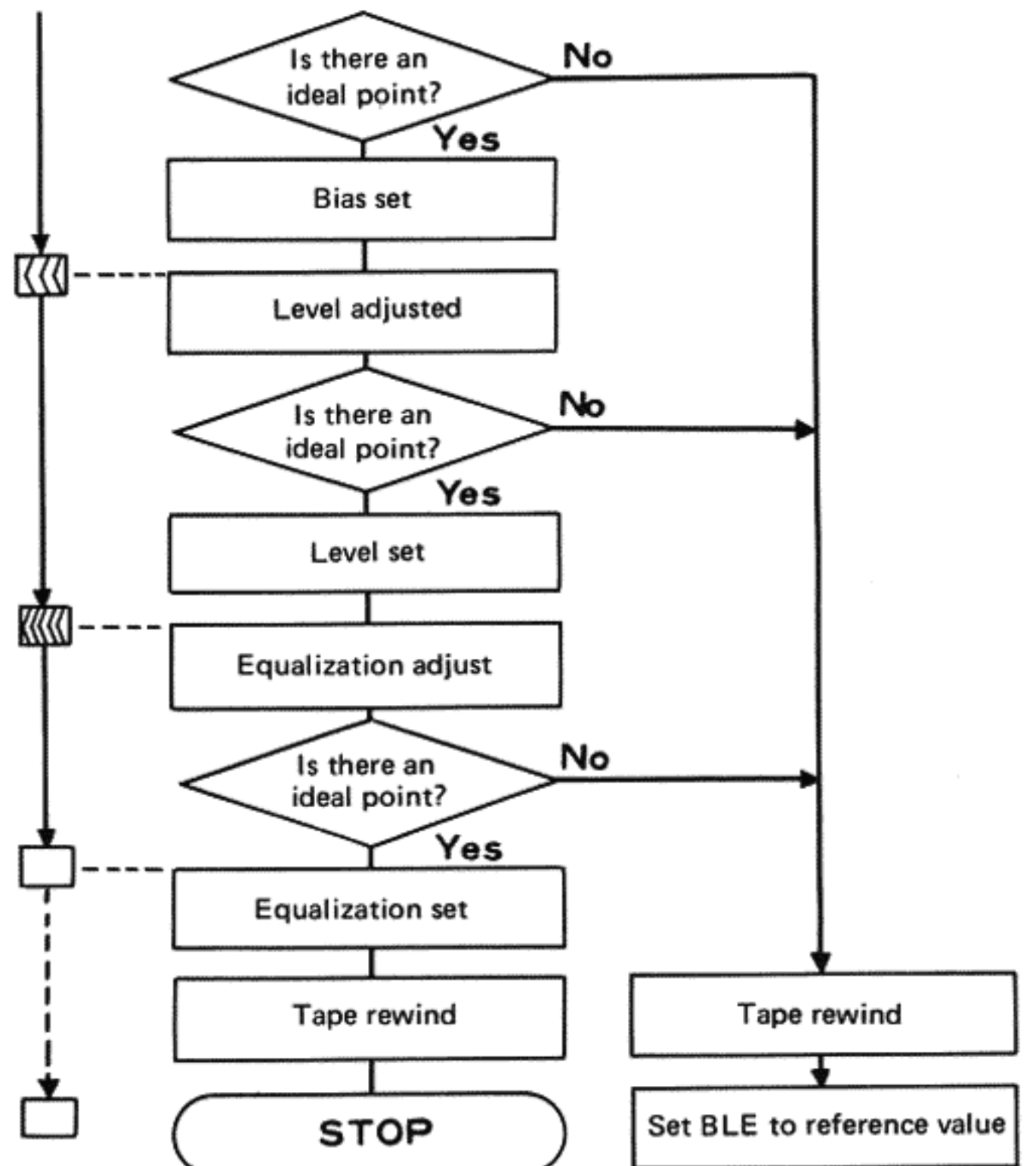
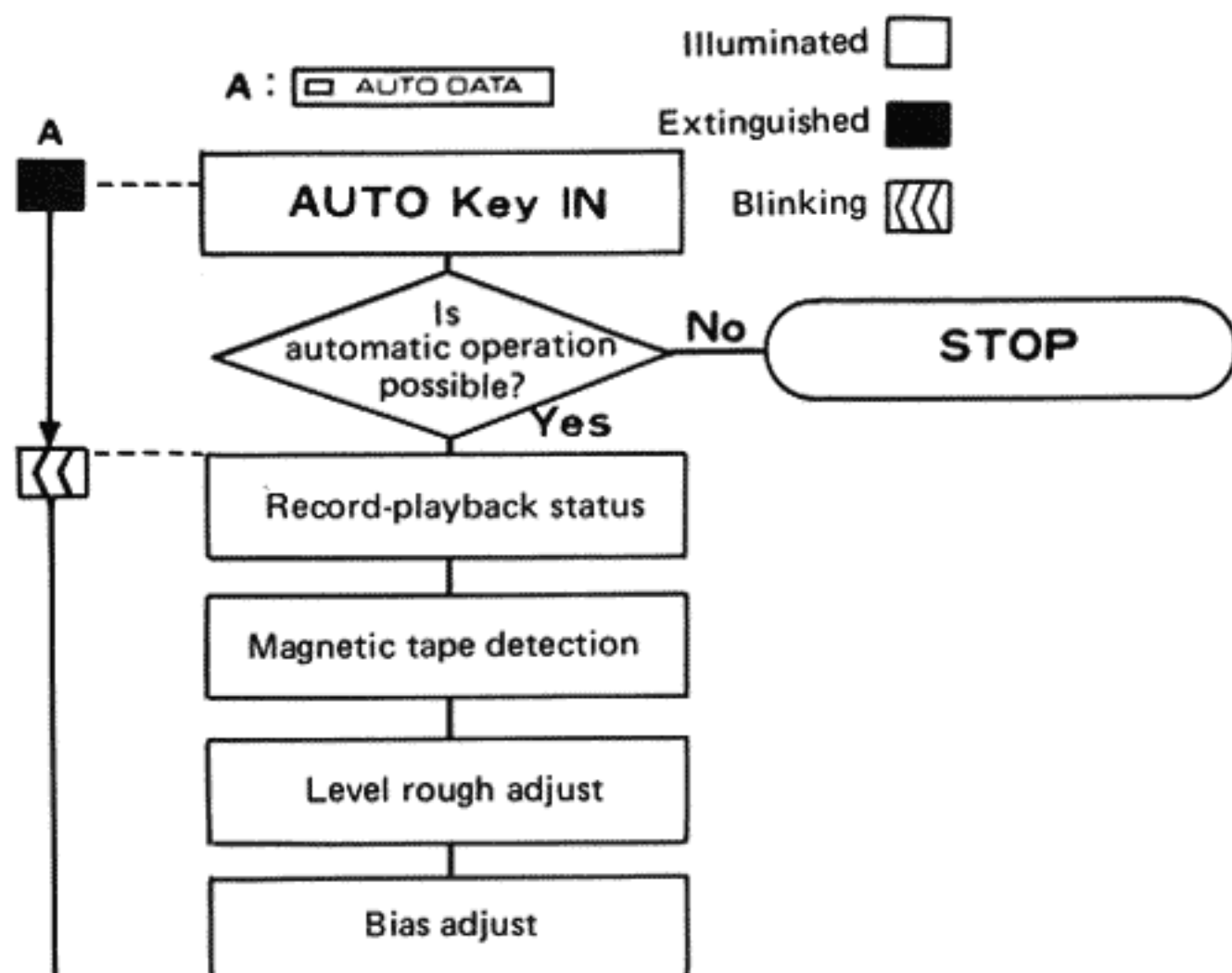

AUTO BLE system automatic adjustment flow chart

TROUBLESHOOTING

If you think the unit is malfunctioning, perform a check following the instructions listed below prior to contacting a service facility. The problem may be in a maintenance procedure, or attempting an erroneous operation, or a defective or unsuitable tape rather than a problem with the unit itself. If the problem persists after performing the check below, contact the store where you bought the unit or a Pioneer Service Center/Service Station.

Symptom	Probable cause	Remedy
Tape does not travel.	<ol style="list-style-type: none"> 1. Power cord unplugged. 2. Cassette tape improperly loaded. 	<ol style="list-style-type: none"> 1. Plug the power cord securely into an AC outlet. 2. Load the cassette tape properly.
No sound during playback.	<ol style="list-style-type: none"> 1. The output knob is set to the minimum position. 2. The monitor switch is in the SOURCE position. 	<ol style="list-style-type: none"> 1. Set the output knob to the proper level. 2. Release the monitor switch to the TAPE position.
Unit will not record.	<ol style="list-style-type: none"> 1. Cassette tape erasure prevention tabs broken off. 2. Improper connection to amplifier. 	<ol style="list-style-type: none"> 1. Use a different cassette tape, or tape over the erasure prevention tab holes using cellophane tape. 2. Correctly connect the connection cables. (refer to page 3)
Sound is distorted during playback.	<ol style="list-style-type: none"> 1. Volume level is too high. 2. Recorded program is distorted. 3. Head dirty. 4. Head magnetized. 	<ol style="list-style-type: none"> 1. Lower volume level. 2. Use another cassette tape. 3. Clean the heads. (See page 13) 4. Demagnetize the heads. (see page 13)
High frequency sounds not reproduced.	<ol style="list-style-type: none"> 1. Tape not recorded using Dolby NR system and being played back with the Dolby NR switch on. 2. Head magnetized. 3. Head dirty. 	<ol style="list-style-type: none"> 1. Turn Dolby NR switch off. 2. Demagnetize the heads. (see page 13) 3. Clean the heads. (see page 13)
High noise level.	<ol style="list-style-type: none"> 1. Tape recorded using Dolby NR system and being played back with Dolby NR switch off. 2. Head magnetized. 3. Head dirty. 4. Old tape. 	<ol style="list-style-type: none"> 1. Turn the Dolby NR switch on. 2. Demagnetize the heads. (see page 13) 3. Clean the heads. (see page 13) 4. Replace cassette tape.
Remaining time indicator does not operate.	<ol style="list-style-type: none"> 1. The tape capacity selector is not set to the proper setting for the cassette in use. 2. The cassette in use is not compatible with the time indicator function (some commercially pre-recorded tapes). 	<ol style="list-style-type: none"> 1. Set to the correct setting. 2. The remaining time indicator can not be used.
Memory stop does not operate.	<ol style="list-style-type: none"> 1. The INDEX SCAN, BLANK SEARCH, MS/SKIP, or MUSIC REPEAT switch is on. 2. The TIMER switch is in the REC position. 	<ol style="list-style-type: none"> 1. Turn the switch(es) off and try again. See pages 10 and 11 for details. 2. Set to the OFF position.
AUTO BLE operation is interrupted.	<ul style="list-style-type: none"> • The MEMORY switch is depressed. 	<ul style="list-style-type: none"> • Release the MEMORY switch.
AUTO BLE does not operate.	<ul style="list-style-type: none"> • Cassette tape erasure prevention tabs broken off. 	<ul style="list-style-type: none"> • Use a different cassette tape, or tape over the erasure prevention tab holes using cellophane tape.
Tape stops during the rewind mode.	<ul style="list-style-type: none"> • The MEMORY switch is depressed. 	<ul style="list-style-type: none"> • Release the MEMORY switch.

SPECIFICATIONS

System	Compact cassette, 2-channel stereo
Motor	Quartz PLL D.D. motor x 1 (For driving the capstan) Brushless D.D. motor x 2 (For driving the reel)
Heads	"Ribbon Sendust" recording/playback combination head x 1, Erasing head x 1
Fast Winding Time	Approximately 90 seconds (C-60 tape)
Wow and Flutter	No more than 0.03% (WRMS)
Frequency Response	
Auto B.L.E.	30 to 16,000Hz \pm 1.5dB -20dB recording
Normal tape	20 to 19,000Hz (25 to 17,000Hz \pm 3dB)
Chromium dioxide tape	20 to 21,000Hz (25 to 19,000Hz \pm 3dB)
Metal tape	20 to 22,000Hz (25 to 20,000Hz \pm 3dB)
OdB recording (Dolby C-type NR: ON)	
Chromium dioxide tape	25 to 12,000Hz
Metal tape	25 to 16,000Hz
Signal-to-Noise ratio	
Dolby NR OFF	More than 60dB
Dolby B-type NR ON	More than 70dB (at 5kHz)
Dolby C-type NR ON	More than 80dB (at 5kHz)
Harmonic Distortion	No more than 1.0% (0dB)
Input (Sensitivity/Maximum allowable input/Impedance)	
MIC (L, R)	0.3mV/50mV/10k Ω , 6mm diam. jack (Reference MIC impedance; 250 Ω to 10k Ω)
LINE (INPUT) x 2	65mV/25V/120k Ω , Pin jacks
Output (Maximum level/Load impedance)	
LINE (OUTPUT) x 2	500mV/50k Ω , Pin jacks
Headphones	60mV/8 Ω , 6mm diam. jack

Subfunctions

- Auto B.L.E. system
- Auto reverse, auto repeat functions
- Index scan function
- Music repeat function
- MS/SKIP function
- Blank search function
- MS system
- REC muting switch
- Remote control
- Dolby NR system (B type/C type/OFF) with LED indicator lamp
- Stand-by-mechanism with unattended recording
- Auto tape selector (NORM/CrO₂/METAL)
- Full automatic stop mechanism
- Memory stop function
- 2 color digital level meter
- Dual mode tape counter
- Output level control
- Cassette compartment illumination

Miscellaneous

Power Requirements	AC 120V, 60Hz
Power Consumption	50 watts
Dimensions	420(W) x 130(H) x 320(D)mm 16-9/16(W) x 5-1/8(H) x 12-5/8(D)in.
Weight (Without package)	6.5kg (14 lb 5 oz)

Furnished Parts

Connection cord with pin plugs	2
Operating instructions	1

NOTE:

Specifications and the design subject to possible modifications without notice due to improvements.

NOTE:

1. Reference Tapes: Normal & LH: DIN 45513/BLATT6 or equiv.
CrO₂ DIN 45513/BLATT7 (CrO₂) or equiv.
2. Reference Recording Level: Meter 0dB indicating level (160nwb/m magnetic level = Philips cassette reference level)
3. Reference Signal: 333Hz
4. Wow & Flutter: ● JIS [3kHz, with acoustic compensation (weighted), rms value] DIN [3,150Hz, with acoustic compensation (weighted) PEAK value]; DIN 45507
5. Frequency Response: ● Measured at -20dB level, DOLBY NR OFF, level deviation is \pm 6dB without indication.
6. Signal to Noise Ratio: ● Measured at the third harmonic distortion 3% level, weighted (DIN 45513/BLATT7).
7. Sensitivity: Input level (mV) required for reference recording level with input (REC) controls set to maximum.
8. Maximum Allowable Input: While decreasing settings of input (REC) level controls and increasing level at input jacks, this is the maximum input level (mV) at the point where recording amplifier output waveform becomes clipped.
9. Reference Output Level: Playback output level when meter indicates 0dB.
10. Maximum Output Level: Playback output level with respect to reference recording level when output (PLAY) level control is set to maximum.
11. This model doesn't employ with a recording/playback connector (DIN-type).

PIONEER ELECTRONIC CORPORATION 4-1, Meguro 1-Chome, Meguro-ku, Tokyo 153, Japan
U.S. PIONEER ELECTRONICS CORPORATION 85 Oxford Drive, Moonachie, New Jersey 07074, U.S.A.
PIONEER ELECTRONIC (EUROPE) N.V. Luithagen-Haven 9, 2030 Antwerp, Belgium
PIONEER ELECTRONICS AUSTRALIA PTY. LTD. 178-184 Boundary Road, Braeside, Victoria 3195, Australia